



175 TE

ARC MASTER®

INVERTER ARC WELDER



Art # A-08667

Operating Manual

Revision: AC

Issue Date: December 20, 2010

Manual No.: 0-5116

Operating Features:



175
AMP



DC

230
V

1
PHASE

50
60
Hz





WE APPRECIATE YOUR BUSINESS!

Congratulations on your new Thermal Arc product. We are proud to have you as our customer and will strive to provide you with the best service and reliability in the industry. This product is backed by our extensive warranty and world-wide service network. To locate your nearest distributor or service agency call +44 (0) 1257 261 755, or visit us on the web at www.Thermalarc.com.

This Operating Manual has been designed to instruct you on the correct use and operation of your Thermal Arc product. Your satisfaction with this product and its safe operation is our ultimate concern. Therefore please take the time to read the entire manual, especially the Safety Precautions. They will help you to avoid potential hazards that may exist when working with this product.

YOU ARE IN GOOD COMPANY!

The Brand of Choice for Contractors and Fabricators Worldwide.

Thermal Arc is a Global Brand of Arc Welding Products for Thermadyne Industries Inc. We manufacture and supply to major welding industry sectors worldwide including; Manufacturing, Construction, Mining, Automotive, Aerospace, Engineering, Rural and DIY/Hobbyist.

We distinguish ourselves from our competition through market-leading, dependable products that have stood the test of time. We pride ourselves on technical innovation, competitive prices, excellent delivery, superior customer service and technical support, together with excellence in sales and marketing expertise.

Above all, we are committed to develop technologically advanced products to achieve a safer working environment within the welding industry.



WARNINGS

Read and understand this entire manual and your employer's safety practices before installing, operating, or servicing the equipment.

While the information contained in this manual represents the Manufacturer's best judgement, the Manufacturer assumes no liability for its use.

Operating Manual Number 0-5116 for:
Arc Master 175 TE TIG/STICK Package System Part No. W1003003
Arc Master 175 TE Power Source Part No. W1003002

Published by:
Thermadyne Europe
Europa Building
Chorley Industrial Park
Chorley, Lancaster,
England, PR6 7BX

www.thermalarc.com

Copyright © 2009 by
Thermadyne Industries Inc.

© All rights reserved.

Reproduction of this work, in whole or in part, without written permission of the publisher is prohibited.

The publisher does not assume and hereby disclaims any liability to any party for any loss or damage caused by any error or omission in this Manual, whether such error results from negligence, accident, or any other cause.

Publication Date: February 17, 2009
Revision Date: December 20, 2010

Record the following information for Warranty purposes:

Where Purchased: _____

Purchase Date: _____

Equipment Serial #: _____

TABLE OF CONTENTS

SECTION 1:SAFETY INSTRUCTIONS AND WARNINGS	1-1
1.01 Arc Welding Hazards.....	1-1
1.02 Principal Safety Standards.....	1-4
1.03 Symbol Chart.....	1-5
1.04 Precautions De Securite En Soudage A L'arc	1-6
1.05 Dangers relatifs au soudage à l'arc	1-6
1.06 Principales Normes De Securite	1-9
1.07 Graphique de Symbole.....	1-10
1.08 Declaration Of Conformity	1-11
SECTION 2:INTRODUCTION	2-1
2.01 How to Use This Manual.....	2-1
2.02 Equipment Identification	2-1
2.03 Receipt of Equipment.....	2-1
2.04 Description	2-1
2.05 Packaged Items	2-1
2.06 Transportation Methods.....	2-2
2.07 Duty Cycle.....	2-2
2.08 User Responsibility	2-2
2.09 Specifications	2-3
SECTION 3:INSTALLATION	3-1
3.01 Environment	3-1
3.02 Location.....	3-1
3.03 Electrical Input Connections	3-1
3.04 High Frequency Introduction	3-3
3.05 High Frequency Interference.....	3-3
3.06 Electromagnetic Compatibility	3-3
3.07 Setup for Welding	3-4
3.08 Manual Arc (STICK) Setup.....	3-5
3.09 HF TIG/Lift TIG (GTAW) Setup	3-6

TABLE OF CONTENTS

SECTION 4:OPERATION	4-1
4.01 General Safety Precautions.....	4-1
4.02 Overview.....	4-1
4.03 Front Panel	4-2
4.04 SMAW Electrode Polarity.....	4-4
4.05 Effects of Stick Welding Various Materials.....	4-4
4.06 GTAW Electrode Polarity	4-5
4.07 Guide for Selecting Filler Wire	4-5
4.08 Tungsten Electrode Current Ranges.....	4-5
4.09 Shielding Gas Selection	4-5
4.10 Tungsten Electrode Types	4-5
4.11 TIG Welding Parameters for Steel.....	4-6
4.12 Arc Welding Practice.....	4-6
4.13 Welding Position.....	4-7
4.14 Joint Preparations.....	4-8
4.15 Arc Welding Technique	4-8
4.16 The Welder.....	4-9
4.17 Striking the Arc.....	4-9
4.18 Arc Length	4-9
4.19 Rate of Travel.....	4-9
4.20 Making Welded Joints.....	4-9
4.21 Distortion.....	4-11
4.22 The Cause of Distortion	4-11
4.23 Overcoming Distortion Effects	4-11
SECTION 5:SERVICE	5-1
5.01 Routine Maintenance and Inspection.....	5-1
5.02 STICK Welding Problems.....	5-2
5.03 TIG Welding Problems	5-3
5.04 Power Source Problems	5-4
APPENDIX 1: REPLACEMENT PARTS	A-1
APPENDIX 2: OPTIONS AND ACCESSORIES	A-2
LIMITED WARRANTY & WARRANTY SCHEDULE	

SECTION 1: SAFETY INSTRUCTIONS AND WARNINGS



WARNING

PROTECT YOURSELF AND OTHERS FROM POSSIBLE SERIOUS INJURY OR DEATH. KEEP CHILDREN AWAY. PACEMAKER WEARERS KEEP AWAY UNTIL CONSULTING YOUR DOCTOR. DO NOT LOSE THESE INSTRUCTIONS. READ OPERATING/INSTRUCTION MANUAL BEFORE INSTALLING, OPERATING OR SERVICING THIS EQUIPMENT.

Welding products and welding processes can cause serious injury or death, or damage to other equipment or property, if the operator does not strictly observe all safety rules and take precautionary actions.

Safe practices have developed from past experience in the use of welding and cutting. These practices must be learned through study and training before using this equipment. Some of these practices apply to equipment connected to power lines; other practices apply to engine driven equipment. Anyone not having extensive training in welding and cutting practices should not attempt to weld.

Safe practices are outlined in the American National Standard Z49.1 entitled: SAFETY IN WELDING AND CUTTING. This publication and other guides to what you should learn before operating this equipment are listed at the end of these safety precautions. **HAVE ALL INSTALLATION, OPERATION, MAINTENANCE, AND REPAIR WORK PERFORMED ONLY BY QUALIFIED PEOPLE.**

1.01 Arc Welding Hazards



WARNING

ELECTRIC SHOCK can kill.

Touching live electrical parts can cause fatal shocks or severe burns. The electrode and work circuit is electrically live whenever the output is on. The input power circuit and machine internal circuits are also live when power is on. In semiautomatic or automatic wire welding, the wire, wire reel, drive roll housing, and all metal parts touching the welding wire are electrically live. Incorrectly installed or improperly grounded equipment is a hazard.

1. Do not touch live electrical parts.
2. Wear dry, hole-free insulating gloves and body protection.
3. Insulate yourself from work and ground using dry insulating mats or covers.
4. Disconnect input power or stop engine before installing or servicing this equipment. Lock input power disconnect switch open, or remove line fuses so power cannot be turned on accidentally.
5. Properly install and ground this equipment according to its Owner's Manual and national, state, and local codes.
6. Turn off all equipment when not in use. Disconnect power to equipment if it will be left unattended or out of service.
7. Use fully insulated electrode holders. Never dip holder in water to cool it or lay it down on the ground or the work surface. Do not touch holders connected to two welding machines at the same time or touch other people with the holder or electrode.
8. Do not use worn, damaged, undersized, or poorly spliced cables.

9. Do not wrap cables around your body.
10. Ground the workpiece to a good electrical (earth) ground.
11. Do not touch electrode while in contact with the work (ground) circuit.
12. Use only well-maintained equipment. Repair or replace damaged parts at once.
13. In confined spaces or damp locations, do not use a welder with AC output unless it is equipped with a voltage reducer. Use equipment with DC output.
14. Wear a safety harness to prevent falling if working above floor level.
15. Keep all panels and covers securely in place.



WARNING

ARC RAYS can burn eyes and skin; NOISE can damage hearing. Arc rays from the welding process produce intense heat and strong ultraviolet rays that can burn eyes and skin. Noise from some processes can damage hearing.

1. Wear a welding helmet fitted with a proper shade of filter (see ANSI Z49.1 listed in Safety Standards) to protect your face and eyes when welding or watching.
2. Wear approved safety glasses. Side shields recommended.
3. Use protective screens or barriers to protect others from flash and glare; warn others not to watch the arc.
4. Wear protective clothing made from durable, flame-resistant material (wool and leather) and foot protection.
5. Use approved ear plugs or ear muffs if noise level is high.

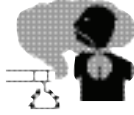

WARNING

FUMES AND GASES can be hazardous to your health.

Welding produces fumes and gases. Breathing these fumes and gases can be hazardous to your health.

1. Keep your head out of the fumes. Do not breathe the fumes.
2. If inside, ventilate the area and/or use exhaust at the arc to remove welding fumes and gases.
3. If ventilation is poor, use an approved air-supplied respirator.
4. Read the Material Safety Data Sheets (MSDSs) and the manufacturer's instruction for metals, consumables, coatings, and cleaners.
5. Work in a confined space only if it is well ventilated, or while wearing an air-supplied respirator. Shielding gases used for welding can displace air causing injury or death. Be sure the breathing air is safe.
6. Do not weld in locations near degreasing, cleaning, or spraying operations. The heat and rays of the arc can react with vapours to form highly toxic and irritating gases.
7. Do not weld on coated metals, such as galvanized, lead, or cadmium plated steel, unless the coating is removed from the weld area, the area is well ventilated, and if necessary, while wearing an air-supplied respirator. The coatings and any metals containing these elements can give off toxic fumes if welded.



WARNING

WELDING can cause fire or explosion.

Sparks and spatter fly off from the welding arc. The flying sparks and hot metal, weld spatter, hot workpiece, and hot equipment can cause fires and burns. Accidental contact of electrode or welding wire to metal objects can cause sparks, overheating, or fire.

1. Protect yourself and others from flying sparks and hot metal.
2. Do not weld where flying sparks can strike flammable material.
3. Remove all flammables within 35' (10.7m) of the welding arc. If this is not possible, tightly cover them with approved covers.
4. Be alert that welding sparks and hot materials from welding can easily go through small cracks and openings to adjacent areas.
5. Watch for fire, and keep a fire extinguisher nearby.
6. Be aware that welding on a ceiling, floor, bulkhead, or partition can cause fire on the hidden side.
7. Do not weld on closed containers such as tanks or drums.
8. Connect work cable to the work as close to the welding area as practical to prevent welding current from travelling long, possibly unknown paths and causing electric shock and fire hazards.
9. Do not use welder to thaw frozen pipes.

Eye protection filter shade selector for welding or cutting (goggles or helmet), from AWS/ANSI Z49.1:1999

Welding or Cutting Operation	Electrode Size Metal Thickness or Welding Current	Filter Shade No.	Welding or Cutting Operation	Electrode Size Metal Thickness or Welding Current	Filter Shade No.
Torch Soldering	All	2	Gas Tungsten Arc Welding		
Torch Brazing	All	3 or 4	Light	Under 50 Amp	10
Oxygen Cutting			Medium	50 to 150 Amp	12
Light	Under 1" (25mm)	3 or 4	Heavy	150 to 500 Amp	14
Medium	1" (25mm) – 6" (150mm)	4 or 5	Atomic Hydrogen Welding	All	12
Heavy	Over 6" (150mm)	5 or 6	Carbon Arc Welding	All	14
Gas Welding			Carbon Arc Gouging		
Light	Under 1/8" (3mm)	4 or 5	Light		12
Medium	1/8" (3mm) – 1/2" (12mm)	5 or 6	Heavy		14
Heavy	Over 1/2" (12mm)	6 or 8	Plasma Arc Welding		
Shielded Metal-Arc Welding (Stick) Electrodes			Light	Under 20 Amp	6 to 8
Light	Under 5/32" (4mm)	10	Light	20 to 100 Amp	10
Medium	Under 5/32" (4mm) - 1/4" (6.4mm)	12	Medium	100 to 400 Amp	12
Heavy	Over 1/4" (6.4mm)	14	Heavy	400 to 800 Amp	14
Gas Metal Arc Welding			Plasma Arc Cutting		
Light	Under 60 Amp	7	Light	Under 300 Amp	9
Light	60 to 160 Amp	11	Medium	300 to 400 Amp	12
Medium	160 to 250 Amp	12	Heavy	400 to 800 Amp	14
Heavy	250 to 500 Amp	14			

- Remove stick electrode from holder or cut off welding wire at contact tip when not in use.



WARNING

FLYING SPARKS AND HOT METAL can cause injury.

Chipping and grinding cause flying metal. As welds cool, they can throw off slag.

- Wear approved face shield or safety goggles. Side shields recommended.
- Wear proper body protection to protect skin.



WARNING

CYLINDERS can explode if damaged.

Shielding gas cylinders contain gas under high pressure. If damaged, a cylinder can explode. Since gas cylinders are normally part of the welding process, be sure to treat them carefully.

- Protect compressed gas cylinders from excessive heat, mechanical shocks, and arcs.
- Install and secure cylinders in an upright position by chaining them to a stationary support or equipment cylinder rack to prevent falling or tipping.
- Keep cylinders away from any welding or other electrical circuits.
- Never allow a welding electrode to touch any cylinder.
- Use only correct shielding gas cylinders, regulators, hoses, and fittings designed for the specific application; maintain them and associated parts in good condition.
- Turn face away from valve outlet when opening cylinder valve.
- Keep protective cap in place over valve except when cylinder is in use or connected for use.
- Read and follow instructions on compressed gas cylinders, associated equipment, and CGA publication P-1 listed in Safety Standards.



WARNING

Engines can be dangerous.

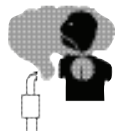

WARNING

ENGINE EXHAUST GASES can kill.

Engines produce harmful exhaust gases.

- Use equipment outside in open, well-ventilated areas.
- If used in a closed area, vent engine exhaust outside and away from any building air intakes.



WARNING

ENGINE FUEL can cause fire or explosion.

Engine fuel is highly flammable.

- Stop engine before checking or adding fuel.
- Do not add fuel while smoking or if unit is near any sparks or open flames.
- Allow engine to cool before fuelling. If possible, check and add fuel to cold engine before beginning job.
- Do not overfill tank — allow room for fuel to expand.
- Do not spill fuel. If fuel is spilled, clean up before starting engine.



WARNING

MOVING PARTS can cause injury.

Moving parts, such as fans, rotors, and belts can cut fingers and hands and catch loose clothing.

- Keep all doors, panels, covers, and guards closed and securely in place.
- Stop engine before installing or connecting unit.
- Have only qualified people remove guards or covers for maintenance and troubleshooting as necessary.
- To prevent accidental starting during servicing, disconnect negative (-) battery cable from battery.
- Keep hands, hair, loose clothing, and tools away from moving parts.
- Reinstall panels or guards and close doors when servicing is finished and before starting engine.



WARNING

SPARKS can cause BATTERY GASES TO EXPLODE; BATTERY ACID can burn eyes and skin.

Batteries contain acid and generate explosive gases.

- Always wear a face shield when working on a battery.
- Stop engine before disconnecting or connecting battery cables.
- Do not allow tools to cause sparks when working on a battery.
- Do not use welder to charge batteries or jump start vehicles.
- Observe correct polarity (+ and -) on batteries.



WARNING

STEAM AND PRESSURIZED HOT COOLANT can burn face, eyes, and skin.

The coolant in the radiator can be very hot and under pressure.

1. Do not remove radiator cap when engine is hot. Allow engine to cool.
2. Wear gloves and put a rag over cap area when removing cap.
3. Allow pressure to escape before completely removing cap.



WARNING

This product, when used for welding or cutting, produces fumes or gases which contain chemicals known to the State of California to cause birth defects and, in some cases, cancer. (California Health & Safety code Sec. 25249.5 et seq.)

NOTE

Considerations About Welding And The Effects of Low Frequency Electric and Magnetic Fields

The following is a quotation from the General Conclusions Section of the U.S. Congress, Office of Technology Assessment, Biological Effects of Power Frequency Electric & Magnetic Fields - Background Paper, OTA-BP-E-63 (Washington, DC: U.S. Government Printing Office, May 1989): "...there is now a very large volume of scientific findings based on experiments at the cellular level and from studies with animals and people which clearly establish that low frequency magnetic fields and interact with, and produce changes in, biological systems. While most of this work is of very high quality, the results are complex. Current scientific understanding does not yet allow us to interpret the evidence in a single coherent framework. Even more frustrating, it does not yet allow us to draw definite conclusions about questions of possible risk or to offer clear science-based advice on strategies to minimize or avoid potential risks."

To reduce magnetic fields in the workplace, use the following procedures.

1. Keep cables close together by twisting or taping them.
2. Arrange cables to one side and away from the operator.
3. Do not coil or drape cable around the body.
4. Keep welding power source and cables as far away from body as practical.

ABOUT PACEMAKERS:

The above procedures are among those also normally recommended for pacemaker wearers. Consult your doctor for complete information.



LEAD WARNING

This product contains chemicals, including lead, or otherwise produces chemicals known to the State of California to cause cancer, birth defects and other reproductive harm. Wash hands after handling. (California Health & Safety Code § 25249.5 et seq.)

1.02 Principal Safety Standards

Safety in Welding and Cutting, ANSI Standard Z49.1, from American Welding Society, 550 N.W. LeJeune Rd., Miami, FL 33126.

Safety and Health Standards, OSHA 29 CFR 1910, from Superintendent of Documents, U.S. Government Printing Office, Washington, D.C. 20402.

Recommended Safe Practices for the Preparation for Welding and Cutting of Containers That Have Held Hazardous Substances, American Welding Society Standard AWS F4.1, from American Welding Society, 550 N.W. LeJeune Rd., Miami, FL 33126.

National Electrical Code, NFPA Standard 70, from National Fire Protection Association, Batterymarch Park, Quincy, MA 02269.

Safe Handling of Compressed Gases in Cylinders, CGA Pamphlet P-1, from Compressed Gas Association, 1235 Jefferson Davis Highway, Suite 501, Arlington, VA 22202.

Code for Safety in Welding and Cutting, CSA Standard W117.2, from Canadian Standards Association, Standards Sales, 178 Rexdale Boulevard, Rexdale, Ontario, Canada M9W 1R3.

Safe Practices for Occupation and Educational Eye and Face Protection, ANSI Standard Z87.1, from American National Standards Institute, 1430 Broadway, New York, NY 10018.

Cutting and Welding Processes, NFPA Standard 51B, from National Fire Protection Association, Batterymarch Park, Quincy, MA 02269.

1.03 Symbol Chart

Note that only some of these symbols will appear on your model.

	On
	Off
	Dangerous Voltage
	Increase/Decrease
	Circuit Breaker
	AC Auxiliary Power
	Fuse
A	Amperage
V	Voltage
Hz	Hertz (cycles/sec)
f	Frequency
	Negative
	Positive
	Direct Current (DC)
	Protective Earth (Ground)
	Line
	Line Connection
	Auxiliary Power
115V 15A 	Receptacle Rating- Auxiliary Power

1	Single Phase
3	Three Phase
	Three Phase Static Frequency Converter- Transformer-Rectifier
	Remote
X	Duty Cycle
%	Percentage
	Panel/Local
	Shielded Metal Arc Welding (SMAW)
	Gas Metal Arc Welding (GMAW)
	Gas Tungsten Arc Welding (GTAW)
	Air Carbon Arc Cutting (CAC-A)
	Constant Current
	Constant Voltage Or Constant Potential
	High Temperature
	Fault Indication
	Arc Force
	Touch Start (GTAW)
	Variable Inductance
	Voltage Input

	Wire Feed Function
	Wire Feed Towards Workpiece With Output Voltage Off.
	Welding Gun
	Purging Of Gas
	Continuous Weld Mode
	Spot Weld Mode
	Spot Time
	Prewflow Time
	Postflow Time
	2 Step Trigger Operation Press to initiate wirefeed and welding, release to stop.
	4 Step Trigger Operation Press and hold for preflow, release to start arc. Press to stop arc, and hold for preflow.
	Burnback Time
IPM	Inches Per Minute
MPM	Meters Per Minute

Art # A-04130

1.04 Precautions De Securite En Soudage A L'arc



MISE EN GARDE

LE SOUDAGE A L'ARC EST DANGEREUX

PROTEGEZ-VOUS, AINSI QUE LES AUTRES, CONTRE LES BLESSURES GRAVES POSSIBLES OU LA MORT. NE LAISSEZ PAS LES ENFANTS S'APPROCHER, NI LES PORTEURS DE STIMULATEUR CARDIAQUE (A MOINS QU'ILS N'AIENT CONSULTE UN MEDECIN). CONSERVEZ CES INSTRUCTIONS. LISEZ LE MANUEL D'OPERATION OU LES INSTRUCTIONS AVANT D'INSTALLER, UTILISER OU ENTREtenir CET EQUIPEMENT.

Les produits et procédés de soudage peuvent sauser des blessures graves ou la mort, de même que des dommages au reste du matériel et à la propriété, si l'utilisateur n'adhère pas strictement à toutes les règles de sécurité et ne prend pas les précautions nécessaires.

En soudage et coupage, des pratiques sécuritaires se sont développées suite à l'expérience passée. Ces pratiques doivent être apprises par étude ou entraînement avant d'utiliser l'équipement. Toute personne n'ayant pas suivi un entraînement intensif en soudage et coupage ne devrait pas tenter de souder. Certaines pratiques concernent les équipements raccordés aux lignes d'alimentation alors que d'autres s'adressent aux groupes électrogènes.

La norme Z49.1 de l'American National Standard, intitulée "SAFETY IN WELDING AND CUTTING" présente les pratiques sécuritaires à suivre. Ce document ainsi que d'autres guides que vous devriez connaître avant d'utiliser cet équipement sont présentés à la fin de ces instructions de sécurité.

SEULES DES PERSONNES QUALIFIEES DOIVENT FAIRE DES TRAVAUX D'INSTALLATION, DE REPARATION, D'ENTRETIEN ET D'ESSAI.

1.05 Dangers relatifs au soudage à l'arc



AVERTISSEMENT

L'ELECTROCUTION PEUT ETRE MORTELLE.

Une décharge électrique peut tuer ou brûler gravement. L'électrode et le circuit de soudage sont sous tension dès la mise en circuit. Le circuit d'alimentation et les circuits internes de l'équipement sont aussi sous tension dès la mise en marche. En soudage automatique ou semi-automatique avec fil, ce dernier, le rouleau ou la bobine de fil, le logement des galets d'entraînement et toutes les pièces métalliques en contact avec le fil de soudage sont sous tension. Un équipement inadéquatement installé ou inadéquatement mis à la terre est dangereux.

1. Ne touchez pas à des pièces sous tension.
2. Portez des gants et des vêtements isolants, secs et non troués.
3. Isolez-vous de la pièce à souder et de la mise à la terre au moyen de tapis isolants ou autres.
4. Déconnectez la prise d'alimentation de l'équipement ou arrêtez le moteur avant de l'installer ou d'en faire l'entretien. Bloquez le commutateur en circuit ouvert ou enlevez les fusibles de l'alimentation afin d'éviter une mise en marche accidentelle.
5. Veuillez à installer cet équipement et à le mettre à la terre selon le manuel d'utilisation et les codes nationaux, provinciaux et locaux applicables.
6. Arrêtez tout équipement après usage. Coupez l'alimentation de l'équipement s'il est hors d'usage ou inutilisé.

7. N'utilisez que des porte-électrodes bien isolés. Ne jamais plonger les porte-électrodes dans l'eau pour les refroidir. Ne jamais les laisser traîner par terre ou sur les pièces à souder. Ne touchez pas aux porte-électrodes raccordés à deux sources de courant en même temps. Ne jamais toucher quelqu'un d'autre avec l'électrode ou le porte-électrode.
8. N'utilisez pas de câbles électriques usés, endommagés, mal épissés ou de section trop petite.
9. N'enroulez pas de câbles électriques autour de votre corps.
10. N'utilisez qu'une bonne prise de masse pour la mise à la terre de la pièce à souder.
11. Ne touchez pas à l'électrode lorsqu'en contact avec le circuit de soudage (terre).
12. N'utilisez que des équipements en bon état. Réparez ou remplacez aussitôt les pièces endommagées.
13. Dans des espaces confinés ou mouillés, n'utilisez pas de source de courant alternatif, à moins qu'il soit muni d'un réducteur de tension. Utilisez plutôt une source de courant continu.
14. Portez un harnais de sécurité si vous travaillez en hauteur.
15. Fermez solidement tous les panneaux et les capots.

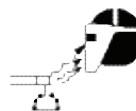

AVERTISSEMENT

LE RAYONNEMENT DE L'ARC PEUT BRÛLER LES YEUX ET LA PEAU; LE BRUIT PEUT ENDOMMAGER L'OUÏE.

L'arc de soudage produit une chaleur et des rayons ultraviolets intenses, susceptibles de brûler les yeux et la peau. Le bruit causé par certains procédés peut endommager l'ouïe.

1. Portez une casque de soudeur avec filtre oculaire de nuance appropriée (consultez la norme ANSI Z49 indiquée ci-après) pour vous protéger le visage et les yeux lorsque vous soudez ou que vous observez l'exécution d'une soudure.
2. Portez des lunettes de sécurité approuvées. Des écrans latéraux sont recommandés.
3. Entourez l'aire de soudage de rideaux ou de cloisons pour protéger les autres des coups d'arc ou de l'éblouissement; avertissez les observateurs de ne pas regarder l'arc.
4. Portez des vêtements en matériaux ignifuges et durables (laine et cuir) et des chaussures de sécurité.
5. Portez un casque antibruit ou des bouchons d'oreille approuvés lorsque le niveau de bruit est élevé.
4. Lisez les fiches signalétiques et les consignes du fabricant relatives aux métaux, aux produits consommables, aux revêtements et aux produits nettoyants.
5. Ne travaillez dans un espace confiné que s'il est bien ventilé; sinon, portez un respirateur à adduction d'air. Les gaz protecteurs de soudage peuvent déplacer l'oxygène de l'air et ainsi causer des malaises ou la mort. Assurez-vous que l'air est propre à la respiration.
6. Ne soudez pas à proximité d'opérations de dégraissage, de nettoyage ou de pulvérisation. La chaleur et les rayons de l'arc peuvent réagir avec des vapeurs et former des gaz hautement toxiques et irritants.
7. Ne soudez des tôles galvanisées ou plaquées au plomb ou au cadmium que si les zones à souder ont été grattées à fond, que si l'espace est bien ventilé; si nécessaire portez un respirateur à adduction d'air. Car ces revêtements et tout métal qui contient ces éléments peuvent dégager des fumées toxiques au moment du soudage.



AVERTISSEMENT

LES VAPEURS ET LES FUMÉES SONT DANGEREUSES POUR LA SANTÉ.

Le soudage dégage des vapeurs et des fumées dangereuses à respirer.

1. Eloignez la tête des fumées pour éviter de les respirer.
2. A l'intérieur, assurez-vous que l'aire de soudage est bien ventilée ou que les fumées et les vapeurs sont aspirées à l'arc.
3. Si la ventilation est inadéquate, portez un respirateur à adduction d'air approuvé.



AVERTISSEMENT

LE SOUDAGE PEUT CAUSER UN INCENDIE OU UNE EXPLOSION

L'arc produit des étincelles et des projections. Les particules volantes, le métal chaud, les projections de soudure et l'équipement surchauffé peuvent causer un incendie et des brûlures. Le contact accidentel de l'électrode ou du fil-électrode avec un objet métallique peut provoquer des étincelles, un échauffement ou un incendie.

SELECTION DES NUANCES DE FILTRES OCULAIRES POUR LA PROTECTION DES YEUX EN COUPAGE ET SOUDAGE (selon AWS à 8.2-73)					
Opération de coupage ou soudage	Dimension d'électrode ou Epiasseur de métal ou Intensité de courant	Nuance de filtre oculaire	Opération de coupage ou soudage	Dimension d'électrode ou Epiasseur de métal ou Intensité de courant	Nuance de filtre oculaire
Brassage tendre au chalumeau	toutes conditions	2	Soudage à l'arc sous gaz avec fil plein (GMAW)		
Brassage fort au chalumeau	toutes conditions	3 ou 4	métaux non-ferreux	toutes conditions	11
Oxycoupage			métaux ferreux	toutes conditions	12
mince	moins de 1 po. (25 mm)	2 ou 3	Soudage à l'arc sous gaz avec électrode de tungstène (GTAW)	toutes conditions	12
moyen	de 1 à 6 po. (25 à 150 mm)	4 ou 5	Soudage à l'hydrogène atomique (AHW)	toutes conditions	12
épais	plus de 6 po. (150 mm)	5 ou 6	Soudage à l'arc avec électrode de carbone (CAW)	toutes conditions	12
Soudage aux gaz			Soudage à l'arc Plasma (PAW)	toutes dimensions	12
mince	moins de 1/8 po. (3 mm)	4 ou 5	Gougeage Air-Arc avec électrode de carbone		
moyen	de 1/8 à 1/2 po. (3 à 12 mm)	5 ou 6	mince		12
épais	plus de 1/2 po. (12 mm)	6 ou 8	épais		14
Soudage à l'arc avec électrode enrobées (SMAW)	moins de 5/32 po. (4 mm)	10	Coupage à l'arc Plasma (PAC)		
	5/32 à 1/4 po. (4 à 6.4 mm)	12	mince	moins de 300 ampères	9
	plus de 1/4 po. (6.4 mm)	14	moyen	de 300 à 400 ampères	12
			épais	plus de 400 ampères	14

1. Protégez-vous, ainsi que les autres, contre les étincelles et du métal chaud.
2. Ne soudez pas dans un endroit où des particules volantes ou des projections peuvent atteindre des matériaux inflammables.
3. Enlevez toutes matières inflammables dans un rayon de 10, 7 mètres autour de l'arc, ou couvrez-les soigneusement avec des bâches approuvées.
4. Méfiez-vous des projections brûlantes de soudage susceptibles de pénétrer dans des aires adjacentes par de petites ouvertures ou fissures.
5. Méfiez-vous des incendies et gardez un extincteur à portée de la main.
6. N'oubliez pas qu'une soudure réalisée sur un plafond, un plancher, une cloison ou une paroi peut enflammer l'autre côté.
7. Ne soudez pas un récipient fermé, tel un réservoir ou un baril.
8. Connectez le câble de soudage le plus près possible de la zone de soudage pour empêcher le courant de suivre un long parcours inconnu, et prévenir ainsi les risques d'électrocution et d'incendie.
9. Ne dégelez pas les tuyaux avec une source de courant.
10. Otez l'électrode du porte-électrode ou coupez le fil au tube-contact lorsqu'inutilisé après le soudage.
11. Portez des vêtements protecteurs non huileux, tels des gants en cuir, une chemise épaisse, un pantalon revers, des bottines de sécurité et un casque.
3. Eloignez les bouteilles de tout circuit électrique ou de tout soudage.
4. Empêchez tout contact entre une bouteille et une électrode de soudage.
5. N'utilisez que des bouteilles de gaz protecteur, des détendeurs, des boyaux et des raccords conçus pour chaque application spécifique; ces équipements et les pièces connexes doivent être maintenus en bon état.
6. Ne placez pas le visage face à l'ouverture du robinet de la bouteille lors de son ouverture.
7. Laissez en place le chapeau de bouteille sauf si en utilisation ou lorsque raccordé pour utilisation.
8. Lisez et respectez les consignes relatives aux bouteilles de gaz comprimé et aux équipements connexes, ainsi que la publication P-1 de la CGA, identifiée dans la liste de documents ci-dessous.

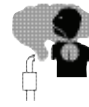

AVERTISSEMENT

LES MOTEURS PEUVENT ETRE DANGEREUX

LES GAZ D'ECHAPPEMENT DES MOTEURS PEUVENT ETRE MORTELS.

Les moteurs produisent des gaz d'échappement nocifs.

1. Utilisez l'équipement à l'extérieur dans des aires ouvertes et bien ventilées.
2. Si vous utilisez ces équipements dans un endroit confiné, les fumées d'échappement doivent être envoyées à l'extérieur, loin des prises d'air du bâtiment.



AVERTISSEMENT

LES ETINCELLES ET LES PROJECTIONS BRULANTES PEUVENT CAUSER DES BLESSURES.

Le piquage et le meulage produisent des particules métalliques volantes. En refroidissant, la soudure peut projeter des éclats de laitier.

1. Portez un écran facial ou des lunettes protectrices approuvées. Des écrans latéraux sont recommandés.
2. Portez des vêtements appropriés pour protéger la peau.



AVERTISSEMENT

LE CARBURANT PEUT CAUSER UN INCENDIE OU UNE EXPLOSION.

Le carburant est hautement inflammable.

1. Arrêtez le moteur avant de vérifier le niveau de carburant ou de faire le plein.
2. Ne faites pas le plein en fumant ou proche d'une source d'étincelles ou d'une flamme nue.
3. Si c'est possible, laissez le moteur refroidir avant de faire le plein de carburant ou d'en vérifier le niveau au début du soudage.
4. Ne faites pas le plein de carburant à ras bord: prévoyez de l'espace pour son expansion.
5. Faites attention de ne pas renverser de carburant. Nettoyez tout carburant renversé avant de faire démarrer le moteur.



AVERTISSEMENT

LES BOUTEILLES ENDOMMAGEES PEUVENT EXPLOSER

Les bouteilles contiennent des gaz protecteurs sous haute pression. Des bouteilles endommagées peuvent exploser. Comme les bouteilles font normalement partie du procédé de soudage, traitez-les avec soin.

1. Protégez les bouteilles de gaz comprimé contre les sources de chaleur intense, les chocs et les arcs de soudage.
2. Enchaînez verticalement les bouteilles à un support ou à un cadre fixe pour les empêcher de tomber ou d'être renversées.



AVERTISSEMENT

DES PIECES EN MOUVEMENT PEUVENT CAUSER DES BLESSURES.

Des pièces en mouvement, tels des ventilateurs, des rotors et des courroies peuvent couper doigts et mains, ou accrocher des vêtements amples.

1. Assurez-vous que les portes, les panneaux, les capots et les protecteurs soient bien fermés.
2. Avant d'installer ou de connecter un système, arrêtez le moteur.
3. Seules des personnes qualifiées doivent démonter des protecteurs ou des capots pour faire l'entretien ou le dépannage nécessaire.
4. Pour empêcher un démarrage accidentel pendant l'entretien, débranchez le câble d'accumulateur à la borne négative.
5. N'approchez pas les mains ou les cheveux de pièces en mouvement; elles peuvent aussi accrocher des vêtements amples et des outils.
6. Réinstallez les capots ou les protecteurs et fermez les portes après des travaux d'entretien et avant de faire démarrer le moteur.

**AVERTISSEMENT**

DES ÉTINCELLES PEUVENT FAIRE EXPLOSER UN ACCUMULATEUR; L'ELECTROLYTE D'UN ACCUMULATEUR PEUT BRULER LA PEAU ET LES YEUX.

Les accumulateurs contiennent de l'électrolyte acide et dégagent des vapeurs explosives.

1. Portez toujours un écran facial en travaillant sur un accumulateur.
2. Arrêtez le moteur avant de connecter ou de déconnecter des câbles d'accumulateur.
3. N'utilisez que des outils anti-étincelles pour travailler sur un accumulateur.
4. N'utilisez pas une source de courant de soudage pour charger un accumulateur ou survolter momentanément un véhicule.
5. Utilisez la polarité correcte (+ et -) de l'accumulateur.

**AVERTISSEMENT**

LA VAPEUR ET LE LIQUIDE DE REFROIDISSEMENT BRULANT SOUS PRESSION PEUVENT BRULER LA PEAU ET LES YEUX.

Le liquide de refroidissement d'un radiateur peut être brûlant et sous pression.

1. N'ôtez pas le bouchon de radiateur tant que le moteur n'est pas refroidi.

2. Mettez des gants et posez un torchon sur le bouchon pour l'ôter.
3. Laissez la pression s'échapper avant d'ôter complètement le bouchon.

**PLOMB AVERTISSEMENT**

Ce produit contient des produits chimiques, comme le plomb, ou engendre des produits chimiques, reconnus par l'état de Californie comme pouvant être à l'origine de cancer, de malformations fœtales ou d'autres problèmes de reproduction. Il faut se laver les mains après toute manipulation. (Code de Californie de la sécurité et santé, paragraphe 25249.5 et suivants)

1.06 Principales Normes De Sécurité

Safety in Welding and Cutting, norme ANSI Z49.1, American Welding Society, 550 N.W. LeJeune Rd., Miami, FL 33128.

Safety and Health Standards, OSHA 29 CFR 1910, Superintendent of Documents, U.S. Government Printing Office, Washington, D.C. 20402.

Recommended Safe Practices for the Preparation for Welding and Cutting of Containers That Have Held Hazardous Substances, norme AWS F4.1, American Welding Society, 550 N.W. LeJeune Rd., Miami, FL 33128.

National Electrical Code, norme 70 NFPA, National Fire Protection Association, Batterymarch Park, Quincy, MA 02269.

Safe Handling of Compressed Gases in Cylinders, document P-1, Compressed Gas Association, 1235 Jefferson Davis Highway, Suite 501, Arlington, VA 22202.

Code for Safety in Welding and Cutting, norme CSA W117.2 Association canadienne de normalisation, Standards Sales, 276 Rexdale Boulevard, Rexdale, Ontario, Canada M9W 1R3.

1.07 Graphique de Symbole

Seulement certains de ces symboles apparaîtront sur votre modèle.

	Sous Tension
	Hors Tension
	Tension dangereuse
	Augmentez/Diminuer
	Disjoncteur
	Source AC Auxiliaire
	Fusible
A	Intensité de Courant
V	Tension
Hz	Hertz (cycles/sec)
f	Fréquence
	Négatif
	Positif
	Courant Continue (DC)
	Terre de Protection
	Ligne
	Connexion de la Ligne
	Source Auxiliaire
115V 15A 	Classement de Prise-Source Auxiliaire

1	Mono Phasé
3	Trois Phasé
	Tri-Phase Statique Fréquence Convertisseur Transformateur-Redresseur
	Distant
X	Facteur de Marche
%	Pourcentage
	Panneau/Local
	Soudage Arc Electrique Avec Electrode Enrobé (SMAW)
	Soudage à L'arc Avec Fil Electrodes Fusible (GMAW)
	Soudage à L'arc Avec Electrode Non Fusible (GTAW)
	Decoupe Arc Carbone (CAC-A)
	Courant Constant
	Tension Constante Ou Potentiel Constant
	Haute Température
	Force d'Arc
	Amorçage de L'arc au Contact (GTAW)
	Inductance Variable
	Tension

	Déroulement du Fil
	Alimentation du Fil Vers la Pièce de Fabrication Hors Tension
	Torch de Soudage
	Purge Du Gaz
	Mode Continu de Soudure
	Soudure Par Point
	Duréc du Pulse
	Durée de Pré-Débit
	Durée de Post-Débit
<p>Détente à 2-Temps</p> <p>Appuyez pour dèruarer l'alimentation du fils et la soudure, le relâcher pour arrêter.</p>	
<p>Détente à 4-Temps</p> <p>Maintenez appuyez pour pré-débit, relaitez pour initier l'arc. Appuyez pour arrêter l'arc, et mainteuir pour pré-débit.</p>	
	Problème de Terre
IPM	Pouces Par Minute
MPM	Mètres Par Minute

Art # A-07639

1.08 Declaration Of Conformity

Manufacturer: Thermadyne Corporation
Address: 82 Benning Street
West Lebanon, New Hampshire 03784
USA



The equipment described in this manual conforms to all applicable aspects and regulations of the 'Low Voltage Directive' (European Council Directive 73/23/EEC as amended by Council Directive 93/68/EEC) and to the National legislation for the enforcement of this Directive.

The equipment described in this manual conforms to all applicable aspects and regulations of the "EMC Directive" (European Council Directive 89/336/EEC) and to the National legislation for the enforcement of this Directive.

Serial numbers are unique with each individual piece of equipment and details description, parts used to manufacture a unit and date of manufacture.

National Standard and Technical Specifications

The product is designed and manufactured to a number of standards and technical requirements. Among them are:

- GENELEC EN50199 EMC Product Standard for Arc Welding Equipment.
- ISO/IEC 60974-1 (BS 638-PT10) (EN 60 974-1) (EN50192) (EN50078) applicable to welding equipment and associated accessories.
- For environments with increased hazard of electrical shock, Power Supplies bearing the S mark conform to EN50192 when used in conjunction with hand torches with exposed cutting tips, if equipped with properly installed standoff guides.
- Extensive product design verification is conducted at the manufacturing facility as part of the routine design and manufacturing process. This is to ensure the product is safe, when used according to instructions in this manual and related industry standards, and performs as specified. Rigorous testing is incorporated into the manufacturing process to ensure the manufactured product meets or exceeds all design specifications.

Thermadyne has been manufacturing products for more than 30 years, and will continue to achieve excellence in our area of manufacture.

Manufacturers responsible representative:

Steve Ward
Operations Director
Thermadyne Europe
Europa Building
Chorley N Industrial Park
Chorley, Lancashire,
England PR6 7BX

SECTION 2: INTRODUCTION

2.01 How to Use This Manual

This Operating Manual applies the part numbers listed on page i. If none are underlined, they are all covered by this manual. To ensure safe operation, read the entire manual, including the chapter on safety instructions and warnings. Throughout this manual, the word WARNING, CAUTION and NOTE may appear. Pay particular attention to the information provided under these headings. These special annotations are easily recognized as follows:



WARNING

Gives information regarding possible personal injury. Warnings will be enclosed in a box such as this.



CAUTION

Refers to possible equipment damage. Cautions will be shown in bold type.

NOTE

Offers helpful information concerning certain operating procedures. Notes will be shown in italics.

2.02 Equipment Identification

The unit's identification number (specification or part number), model, and serial number usually appear on a nameplate attached to the machine. Equipment which does not have a nameplate attached to the machine is identified only by the specification or part number printed on the shipping container. Record these numbers for future reference.

2.03 Receipt of Equipment

When you receive the equipment, check it against the invoice to make sure it is complete and inspect the equipment for possible damage due to shipping. If there is any damage, notify the carrier immediately to file a claim. Furnish complete information concerning damage claims or shipping errors to the location in your area listed in the inside back cover of this manual. Include all equipment identification numbers as described above along with a full description of the parts in error.

2.04 Description

ArcMaster 175 TE

This compact heavy duty, inverter welding machine has infinitely adjustable welding current from 5 to 175 amps. It runs standard general purpose .098" (2.5mm) electrodes for light gauge work, generally less than .118" (3.0mm) thick, and 1/8" (3.2mm) or .157" (4.0mm) electrodes for heavier material. The unit also has a lift TIG and HF TIG function that offers stable TIG welding characteristics when used with a suitable TIG torch and shielding gas.

2.05 Packaged Items

- 175 TE Inverter Power Source
- Electrode Holder with 5m Lead (16mm²)
- Work Clamp with 5m Lead (16mm²)
- TIG Torch
- TIG Torch Accessories
- Plastic Tool Case
- Operating Manual

2.06 Transportation Methods



CAUTION

ELECTRIC SHOCK can kill. DO NOT TOUCH live electric parts. Disconnect input power conductors from de-energized supply line before moving the welding power source.



WARNING

FALLING EQUIPMENT can cause serious personal injury and equipment damage.

Lift unit with handle on top of case. Use handcart or similar device of adequate capacity. If using a fork lift vehicle, place secure unit on a proper skid before transporting.

2.07 Duty Cycle

The rated duty cycle of a Welding Power Source, is a statement of the time it may be operated at its rated welding current output without exceeding the temperature limits of the insulation of the component parts. To explain the 10 minute duty cycle period the following example is used. Suppose a Welding Power Source is designed to operate at a 20% duty cycle, 175 amperes at 26.8 volts. This means that it has been designed and built to provide the rated amperage (175A) for 2 minutes, i.e. arc welding time, out of every 10 minute period (20% of 10 minutes is 2 minutes). During the other 8 minutes of the 10 minute period the Welding Power Source must idle and allowed to cool.

2.08 User Responsibility

This equipment will perform as per the information contained herein when installed, operated, maintained and repaired in accordance with the instructions provided. This equipment must be checked periodically. Defective equipment (including welding leads) should not be used. Parts that are broken, missing, plainly worn, distorted or contaminated, should be replaced immediately. Should such repairs or replacements become necessary, it is recommended that such repairs be carried out by appropriately qualified persons approved by Thermal Arc. Advice in this regard can be obtained by contacting accredited Thermal Arc Distributor.

This equipment or any of its parts should not be altered from standard specification without prior written approval of Thermal Arc. The user of this equipment shall have the sole responsibility for any malfunction which results from improper use or unauthorised modification from standard specification, faulty maintenance, damage or improper repair by anyone other than appropriately qualified persons approved by Thermal Arc.

2.09 Specifications

Power Source Part Number	W1003002
Welding Output	
	5 - 175 Amps
Nominal DC Open Circuit Voltage (OCV)	65
Welding Output, 104°F (40°C), 10 min. (quoted figures refer to SMAW output)	175A @ 20%, 27.0V 110A @ 60%, 24.4V 80A @ 100%, 23.2V
Rated Input Current (A) for STICK Welding	40 Amps I _o = 175A @ 27V
Rated Input Current (A) for TIG Welding	24 Amps I _o = 175A @ 17V
Rated Output for STICK Welding	175A @ 20%, 27V
Rated Output for TIG Welding	175A @ 20%, 17V
Duty Cycle (%)	20% @ 175
Welder Type	Inverter Power Source with High Frequency
Output Terminal Type	Dinse™ 50
Mains Power	
Number of Phases	Single Phase
Nominal Supply Voltage	230V
Nominal Supply Frequency	50/60 Hz
Effective Input Current (I _{1eff})	17.9 Amps
Maximum Input Current (I _{1 max})	Δ 40 Amps
Single Phase Generator Requirements	10 KVA
Classification	
Protection Class	IP23S
Standard(s)	IEC 60974-1
Cooling Method	Fan Cooled
Dimensions and Weight	
Welding Power Source Mass	16.53lb (7.5kg)
Dimension Power Source (DxWxH)	H 13.0" x W5.1" x D 10.0" (H 330mm x W 130mm x D 255mm)

Δ The recommended motor start fuse or thermal circuit breaker size is 40 amp. An individual branch circuit capable of carrying 40 amperes and protected by fuses or circuit breaker is recommended for this application. Fuse size is based on not more than 200 percent of the rated input amperage of the welding power source (Based on Article 630, National Electrical Code).

Thermal Arc continuously strives to produce the best product possible and therefore reserves the right to change, improve or revise the specifications or design of this or any product without prior notice. Such updates or changes do not entitle the buyer of equipment previously sold or shipped to the corresponding changes, updates, improvements or replacement of such items.

The values specified in the table above are optimal values, your values may differ. Individual equipment may differ from the above specifications due to in part, but not exclusively, to any one or more of the following; variations or changes in manufactured components, installation location and conditions and local power grid supply conditions.

**SECTION 3:
INSTALLATION**

3.01 Environment

These units are designed for use in environments with increased hazard of electric shock. Examples of environments with increased hazard of electric shock are:

- A. In locations in which freedom of movement is restricted, so that the operator is forced to perform the work in a cramped (kneeling, sitting or lying) position with physical contact with conductive parts.
- B. In locations which are fully or partially limited by conductive elements, and in which there is a high risk of unavoidable or accidental contact by the operator.
- C. In wet or damp hot locations where humidity or perspiration considerably reduces the skin resistance of the human body and the insulation properties of accessories.

Environments with increased hazard of electric shock do not include places where electrically conductive parts in the near vicinity of the operator, which can cause increased hazard, have been insulated.

3.02 Location

Be sure to locate the welder according to the following guidelines:

- In areas, free from moisture and dust.
- Ambient temperature between 32°F to 104°F (0°C to 40°C).
- In areas, free from oil, steam and corrosive gases.
- In areas, not subjected to abnormal vibration or shock.
- In areas, not exposed to direct sunlight or rain.
- Place at a distance of 12" (300mm) or more from walls or similar that could restrict natural air flow for cooling



WARNING

Thermal Arc advises that this equipment be electrically connected by a qualified electrician.

3.03 Electrical Input Connections



WARNING

ELECTRIC SHOCK can kill; SIGNIFICANT DC VOLTAGE is present after removal of input power.

DO NOT TOUCH live electrical parts.

SHUT DOWN welding power source, disconnect input power employing lockout/tagging procedures. Lockout/tagging procedures consist of padlocking line disconnect switch in open position, removing fuses from fuse box, or shutting off and red-tagging circuit breaker or other disconnecting device.

• Electrical Input Requirements

Operate the welding power source from a single-phase 50/60 Hz, AC power supply. The input voltage must match one of the electrical input voltages shown on the input data label on the unit nameplate. Contact the local electric utility for information about the type of electrical service available, how proper connections should be made, and inspection required. The line disconnect switch provides a safe and convenient means to completely remove all electrical power from the welding power supply whenever necessary to inspect or service the unit.

Do not connect an input (WHITE or BLACK) conductor to the ground terminal.

Do not connect the ground (GREEN) conductor to an input line terminal.

Refer to Figure 3-1:

1. Connect end of ground (GREEN or GREEN/YELLOW) conductor to a suitable ground. Use a grounding method that complies with all applicable electrical codes.
2. Connect ends of line 1 (BLUE) and line 2 (BROWN) input conductors to a de-energized line disconnect switch.
3. Use Table 3-1 as a guide to select line fuses for the disconnect switch.

Input Voltage	Fuse Size
230V	40 Amps

Table 3-1: Electrical Connections

Fuse size is based on not more than 200 percent of the rated input amperage of the welding power source (Based on Article 630, National Electrical Code).

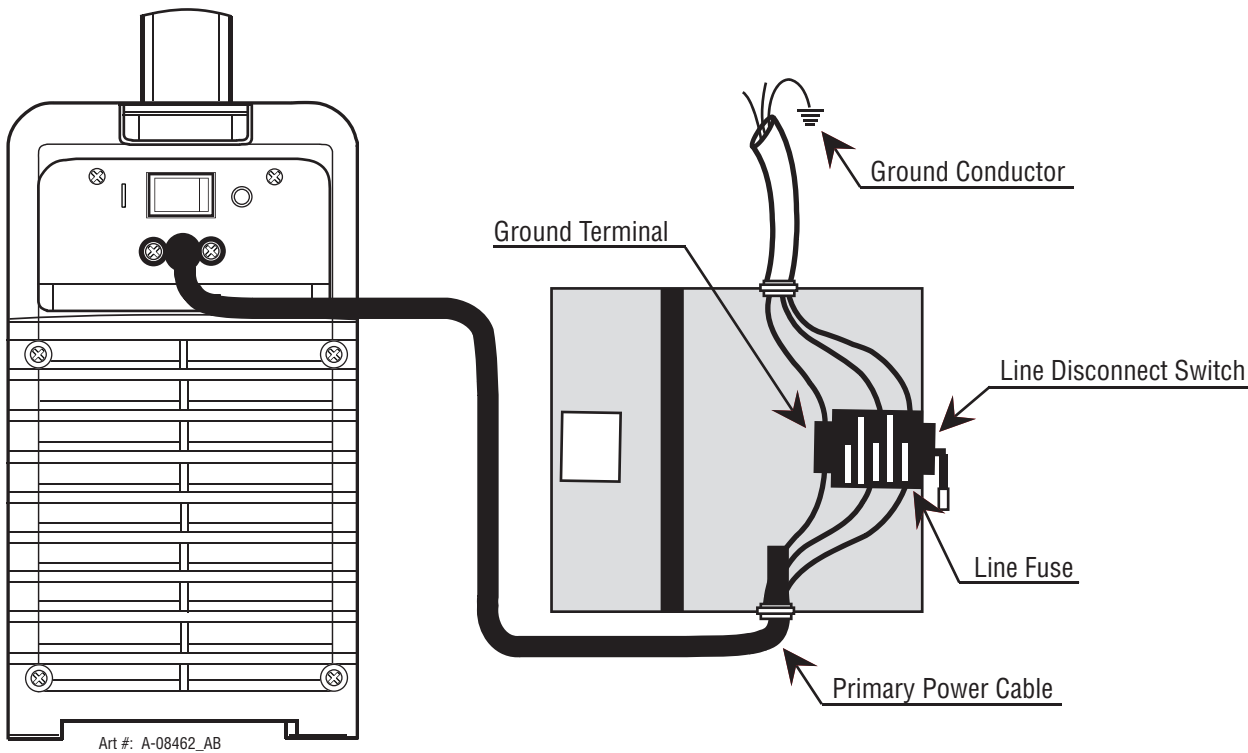

Figure 3-1: Electrical Input Connections

Input Power

Each unit incorporates an INRUSH circuit. When the MAIN CIRCUIT SWITCH is turned on, the inrush circuit provides pre-charging for the input capacitors. A relay in the Power Control Assembly (PCA) will turn on after the input capacitors have charged to operating voltage (after approximately 5 seconds)

NOTE

Damage to the PCA could occur if 265 VAC or higher is applied to the Primary Power Cable.

Model	Primary Supply Lead Size (Factory Fitted)	Minimum Primary Current Circuit Size	Current & Duty Cycle	
			TIG	STICK
Arc Master 175 TE	13 AWG (1.5mm ²)	230V/25A	175A@20%	-
		230V/40A	-	175A@20%

Table 3-2: Primary Supply Lead

3.04 High Frequency Introduction

The importance of correct installation of high frequency welding equipment cannot be overemphasized. Interference due to high frequency initiated or stabilized arc is almost invariably traced to improper installation. The following information is intended as a guide for personnel installing high frequency welding machines.



WARNING:

EXPLOSIVE The high frequency section of this machine has an output similar to a radio transmitter. The machine should NOT be used in the vicinity of blasting operations due to the danger of premature firing.



WARNING:

COMPUTERS It is also possible that operation close to computer installations may cause computer malfunction.

3.05 High Frequency Interference

Interference may be transmitted by a high frequency initiated or stabilized arc welding machine in the following ways:

1. **Direct Radiation:** Radiation from the machine can occur if the case is metal and is not properly grounded. It can occur through apertures such as open access panels. The shielding of the high frequency unit in the Power Source will prevent direct radiation if the equipment is properly grounded.
2. **Transmission via the Supply Lead:** Without adequate shielding and filtering, high frequency energy may be fed to the wiring within the installation (mains) by direct coupling. The energy is then transmitted by both radiation and conduction. Adequate shielding and filtering is provided in the Power Source.
3. **Radiation from Welding Leads:** Radiated interference from welding leads, although pronounced in the vicinity of the leads, diminishes rapidly with distance. Keeping leads as short as possible will minimize this type of interference. Looping and suspending of leads should be avoided where possible.

4. Re-radiation from Unearthed Metallic Objects:

A major factor contributing to interference is re-radiation from unearthed metallic objects close to the welding leads. Effective grounding of such objects will prevent re-radiation in most cases.

3.06 Electromagnetic Compatibility



WARNING

Extra precautions for Electromagnetic Compatibility may be required when this Welding Power Source is used in a domestic situation.

A. Installation and Use - Users Responsibility

The user is responsible for installing and using the welding equipment according to the manufacturer's instructions. If electromagnetic disturbances are detected then it shall be the responsibility of the user of the welding equipment to resolve the situation with the technical assistance of the manufacturer. In some cases this remedial action may be as simple as earthing the welding circuit, see NOTE below. In other cases it could involve constructing an electromagnetic screen enclosing the Welding Power Source and the work, complete with associated input filters. In all cases, electromagnetic disturbances shall be reduced to the point where they are no longer trouble-some.

NOTE

For 230 VAC operation, have a qualified person install according to applicable codes, and instructions.

NOTE

The welding circuit may or may not be earthed for safety reasons. Changing the earthing arrangements should only be authorized by a person who is competent to assess whether the changes will increase the risk of injury, e.g. by allowing parallel welding current return paths which may damage the earth circuits of other equipment. Further guidance is given in IEC 974-13 Arc Welding Equipment - Installation and use (under preparation).

B. Assessment of Area

Before installing welding equipment, the user shall make an assessment of potential electromagnetic problems in the surrounding area. The following shall be taken into account.

3.07 Setup for Welding

NOTE

Conventional operating procedures apply when using the Welding Power Source, i.e. connect work lead directly to work piece and electrode lead is used to hold electrode. Wide safety margins provided by the design ensure that the Welding Power Source will withstand short-term overload without adverse effects. The welding current range values should be used as a guide only. Current delivered to the arc is dependent on the welding arc voltage, and as welding arc voltage varies between different classes of electrodes, welding current at any one setting would vary according to the type of electrode in use. The operator should use the welding current range values as a guide then fine tune the welding current to suit the application.



WARNING

Before connecting the work clamp to the work and inserting the electrode in the electrode holder make sure the Primary power supply is switched off.



CAUTION

Remove any packaging material prior to use. Do not block the air vents at the front or rear of the Welding Power Source.

3.08 Manual Arc (STICK) Setup

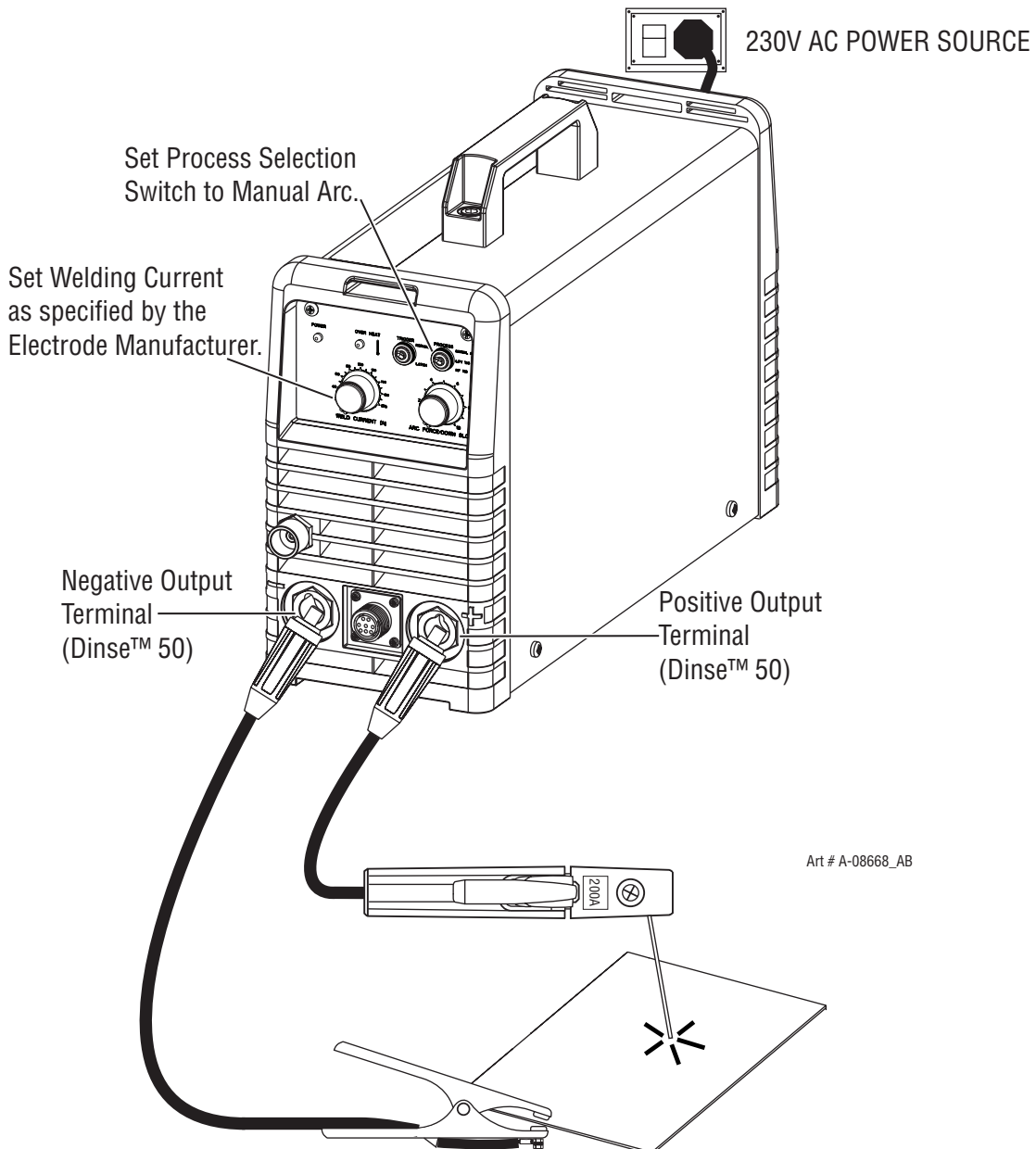

Figure 3-2: Setup for Manual Arc (STICK) Welding

Manual Arc Sequence of Operation

1. Switch the ON/OFF Switch (located on the rear panel) to OFF.
2. Connect the earth clamp lead to the Negative Output Terminal and electrode holder lead to the Positive Output Terminal. Consult the electrode manufacture's packaging for the correct electrode polarity.
3. Plug the Power Source in and switch the power switch ON.
4. Set the Process Switch to Manual Arc.
5. Set the Weld Current control to the desired welding current.
6. Switch the ON/OFF Switch (located on the rear panel) to the ON position. This will immediately energize the power supply up to the output terminals and the electrode holder.
7. Commence welding. If necessary, readjust the Weld Current control to obtain the welding condition required.
8. After completion of welding the Power Source should be left turned ON for 2 to 3 minutes. This allows the fan to run and cool the internal components.
9. Switch the ON/OFF Switch (located on the rear panel) to the OFF position.

3.09 HF TIG/Lift TIG (GTAW) Setup

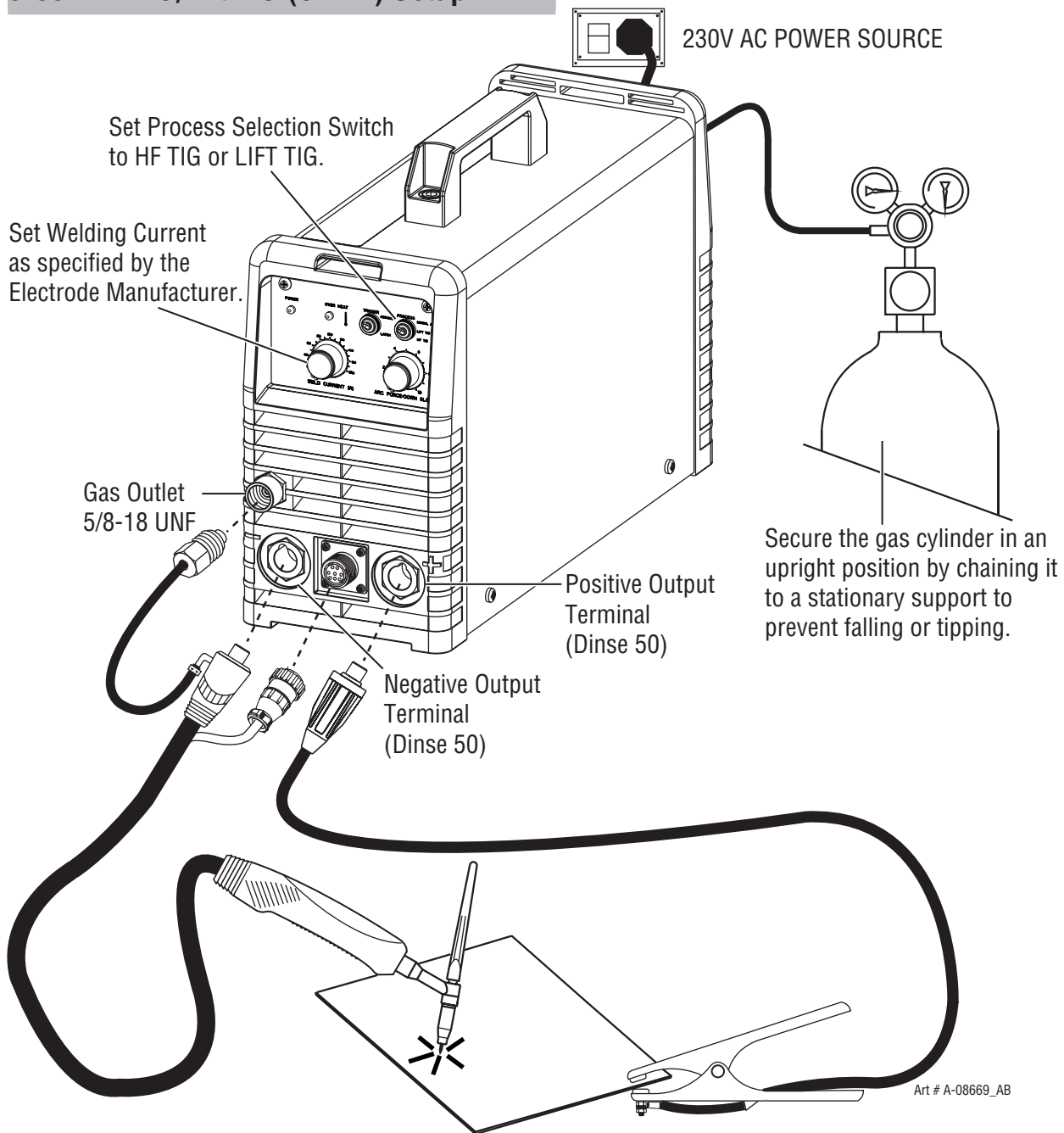

Figure 3-3: Setup for Lift TIG (GTAW) Welding

HF TIG/Lift TIG Sequence of Operation

1. Switch the ON/OFF Switch (located on the rear panel) to OFF.
2. Connect the earth clamp to the Positive Output Terminal, torch cable to the Negative Output Terminal, 8 pin plug to the 8 pin socket and gas hose to the output of an Argon regulator.
3. Plug the Power Source in and switch the power switch ON.
4. Set the Process Selection Switch to HF TIG or LIFT TIG.
5. Set the Weld Current control to the desired welding current.
6. Switch the ON/OFF Switch to the ON position.
7. Depress the TIG torch trigger switch to commence welding. If necessary, readjust the Weld Current control to obtain the welding condition required.
8. After completion of welding the Power Source should be left turned ON for 2 to 3 minutes. This allows the fan to run and cool the internal components.
9. Switch the ON/OFF Switch (located on the rear panel) to the OFF position.

SECTION 4: OPERATION



4.01 General Safety Precautions

Read and understand the safety instructions at the beginning of this manual prior to operating this machine.

**WARNING:**

Be sure to put on proper protective clothing and eye safeguards (welding coat, apron, gloves, and welding helmet, with proper lenses installed). See Safety Instructions and Warnings chapter included in this manual. Neglect of these precautions may result in personal injury.

**WARNING:**

Make all connections to the power source including electrode and work cables, as well as remote control cables, with the power source turned off. These connections could be electrically live with the power switch ON.

4.02 Overview

Conventional operating procedures apply when using the Welding Power Source, i.e. connect work lead directly to work piece and electrode lead is used to hold the electrode. The welding current range values should be used as a guide only. Current delivered to the arc is dependent on the welding arc voltage, and as welding arc voltage varies between different classes of electrode, welding current at any one setting would vary according to the type of electrode in use. The operator should use the welding current range values as a guide then fine tune the welding current to suit the specific application. Refer to the electrode manufacture's literature for further information.

4.03 Front Panel

Front Panel

The welding power source is protected by a self re-setting thermostat. The indicator will illuminate if the duty cycle of the power source has been exceeded. If the Over Heat light illuminates wait for the Over Heat light to extinguish before resuming welding.

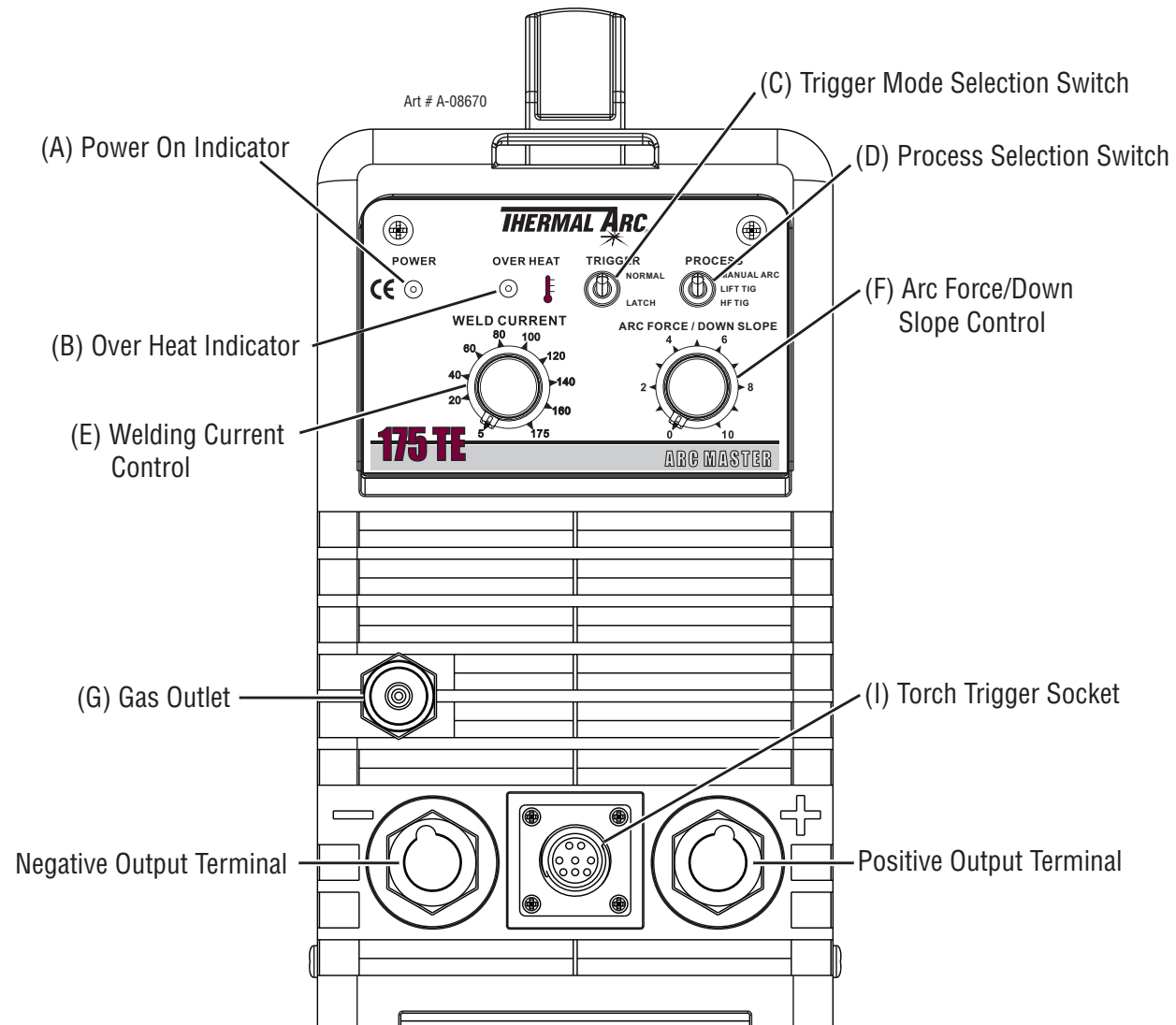

Figure 4-1: 175 TE Control Panel

A. Power ON Indicator

The Power ON Indicator illuminates when the ON/OFF switch is in the ON position and the correct mains voltage is present.

B. Over Heat Indicator

The welding power source is protected by a self resetting thermostat. The indicator will illuminate if the duty cycle of the power source has been exceeded. If the Over Heat light illuminates wait for the Over Heat light to extinguish before resuming welding.

C. Trigger Mode Selection Switch (TIG Mode only)

Normal Mode

Press the TIG Torch Trigger Switch and hold depressed to weld. Release the TIG Torch Trigger Switch to stop welding. Downslope operates in TIG mode only. Whilst welding if the TIG Torch Trigger Switch is released, the welding current ramps down to zero current over a defined period of time. The time period is determined by the Downslope Control Knob (F).

Latch Mode

This mode of welding is mainly used for long weld runs. The operator need only to press the TIG Torch Trigger Switch to activate and then release the TIG Torch Trigger Switch to continue to weld, then press the TIG Torch Trigger Switch again and release the TIG Torch Trigger Switch to stop welding. This eliminates the need for the operator to depress the TIG Torch Trigger Switch for the complete length of the weld. Downslope operates in TIG Mode only. To activate the Downslope function in Latch mode whilst welding, the TIG Torch Trigger Switch must be depressed and held which will ramp the Welding Current down to zero over a defined period of time. The time period is determined by the Downslope Control Knob (F). At any time whilst welding if the TIG Torch Trigger Switch is depressed and released the arc will extinguish immediately.

D. Process Selection Switch

Switches between Manual Arc, Lift TIG and HF TIG modes. Refer to Section 3.08 Setup for Manual Arc Welding and 3.09 Setup for TIG Welding.

E. Welding Current Control

The welding current is increased by turning the Weld Current Control Knob clockwise or decreased by turning the Weld Current Control Knob anticlockwise. The welding current should be set according to the specific application. Refer to application notes in this section for further information.

F. Arc Force/Down Slope Control

Arc Force is effective when in Manual Arc Mode only. Arc Force control provides an adjustable amount of

Arc Force (or “dig”) control. This feature can be particularly beneficial in providing the operator the ability to compensate for variability in joint fit-up in certain situations with particular electrodes. In general increasing the Arc Force control toward ‘10’ (maximum Arc Force) allows greater penetration control to be achieved. Down Slope operates in TIG mode only. It is used to set the time for weld current to ramp down. Refer to Item C (Trigger Mode Selection Switch) for further information regarding Downslope operation.

G. Gas Outlet

The Gas Outlet is a 5/8-18 UNF female gas fitting and is utilised for the connection of a suitable TIG Torch.

H. Post Gas Flow

Post Gas Flow is the time Gas flows after the arc has extinguished. This is used to cool and reduce oxidisation of the Tungsten Electrode. Post Gas Flow time is proportional to the Welding Current. For example if the Welding Current is set to 10 amps the Post Gas Flow time will be approximately 3 +0/-1 seconds. For a Welding Current set to 175 Amps the Post Gas Flow time will be approximately 6 +1/-0 seconds. The Post Gas Flow time cannot be adjusted independently of the Welding Current.

I. Torch Trigger Socket

The 8 pin Torch Trigger Socket is used to connect the TIG Torch Trigger Switch to the welding Power Source. To make connections, align keyway, insert plug, and rotate threaded collar fully clockwise.

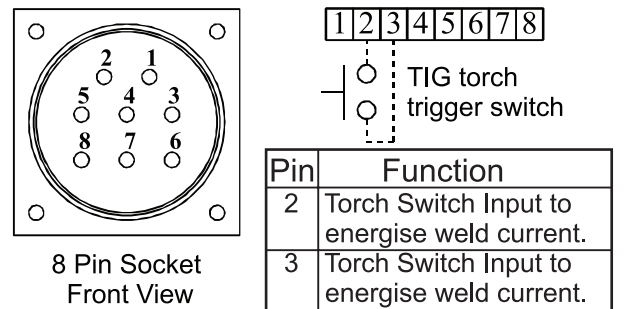

Art # A-08956

NOTE:

Remote Welding Current Control is not available on this model.

J. ON/OFF Switch (located on rear panel not shown)

This switch controls the Mains Supply Voltage to the Power Source.

4.04 SMAW Electrode Polarity

Stick electrodes are generally connected to the "+" Positive Output Terminal and the work lead to the "-" Negative Output Terminal but if in doubt consult the electrode manufacturer's literature for further information.

4.05 Effects of Stick Welding Various Materials

High Tensile and Alloy Steels

The two most prominent effects of welding these steels are the formation of a hardened zone in the weld area, and, if suitable precautions are not taken, the occurrence in this zone of under-bead cracks. Hardened zone and under-bead cracks in the weld area may be reduced by using the correct electrodes, preheating, using higher current settings, using larger electrode sizes, short runs for larger electrode deposits or tempering in a furnace.

Manganese Steels

The effect on manganese steel of slow cooling from high temperatures is to embrittle it. For this reason it is absolutely essential to keep manganese steel cool

during welding by quenching after each weld or skip welding to distribute the heat.

Cast Iron

Most types of cast iron, except white iron, are weldable. White iron, because of its extreme brittleness, generally cracks when attempts are made to weld it. Trouble may also be experienced when welding white-heart malleable, due to the porosity caused by gas held in this type of iron.

Copper and Alloys

The most important factor is the high rate of heat conductivity of copper, making pre-heating of heavy sections necessary to give proper fusion of weld and base metal.

Types of Electrodes

Arc Welding electrodes are classified into a number of groups depending on their applications. There are a great number of electrodes used for specialized industrial purposes which are not of particular interest for everyday general work. These include some low hydrogen types for high tensile steel, cellulose types for welding large diameter pipes, etc. The range of electrodes dealt with in this publication will cover the

Metal Being Joined	Electrode	Comments
Mild Steel	E6013	Ideal electrodes for all general purpose work, features include outstanding operator appeal, easy arc starting, and low spatter.
Mild Steel	E7014	All positional electrode for use on mild and galvanized steel furniture, plates, fences, gates, pipes and tanks, etc. Especially suitable for vertical-down welding.
Cast Iron	99% Nickel	Suitable for joining all cast irons except white cast iron.
Stainless Steel	E318L-16	High corrosion resistance. Ideal for dairy work etc.
Copper, Bronze, Brass, Etc.	Bronze 5.7 ERCUSI-A	Easy to use electrode for marine fittings, water taps and valves, water through floats arms, etc. Also for joining copper to steel and for bronze overlays on steel shafts.
High Alloy Steel, Dissimilar Metals, Crack Resistance, All Hard-To Weld jobs	E312-16	It will weld most problematic job such as springs, shafts, broken joins, mild steel to stainless and alloy steels. Not suitable for aluminium.

4.06 GTAW Electrode Polarity

Connect the TIG torch to the "-" Negative Output Terminal and the work lead to the "+" Positive Output Terminal for direct current straight polarity. Direct current straight polarity is the most widely used polarity for DC TIG welding. It allows limited wear of the electrode since 70% of the heat is concentrated at the work piece.

4.07 Guide for Selecting Filler Wire

Filler Wire Diameter	DC Current (Amps)
.040" (1.0mm)	30-60
1/16" (1.6mm)	60-115
3/32" (2.4mm)	100-165
1/8" (3.2mm)	135-175

4.08 Tungsten Electrode Current Ranges

Electrode Diameter	DC Current
.040" (1.0mm)	25 - 85
1/16" (1.6mm)	50 - 160

4.09 Shielding Gas Selection

Alloy	Shielding Gas
Carbon Steel	Welding Argon
Stainless Steel	Welding Argon
Nickel Alloy	Welding Argon
Copper	Welding Argon
Titanium	Welding Argon

4.10 Tungsten Electrode Types

Electrode Type (Ground Finish)	Welding Application	Features	Colour Code
Thoriated 2%	DC welding of mild steel, stainless steel and copper.	Excellent arc starting, long life, high current carrying capacity.	Red
Ceriated 2%	AC & DC welding of mild steel, stainless steel, copper, aluminum, magnesium and their alloys.	Longer life, more stable arc, easier starting, wider current range, narrower & more concentrated arc.	Grey

4.11 TIG Welding Parameters for Steel

Base Metal	DC Current		Electrode Diameter	Filler Rod Diameter	Argon Gas Flow Rate	Joint Type
	Mild Steel	Stainless Steel				
0.040" (1.0mm)	35-45	20-30	0.040" (1.0mm)	1/16" (1.6mm)	10 CFH (5 LPM)	Butt/Corner
	40-50	25-35				Lap/Filler
0.045"	45-55	30-45	0.040" (1.0mm)	1/16" (1.6mm)	13 CFH (6 LPM)	Butt/Corner
	50-60	35-50				Lap/Filler
1/16" (1.6mm)	60-70	40-60	1/16" (1.6mm)	1/16" (1.6mm)	15 CFH (7 LPM)	Butt/Corner
	70-90	50-70				Lap/Filler
1/8" (3.2mm)	80-100	65-85	1/16" (1.16mm)	3/32" (2.4mm)	15CFH (7 LPM)	Butt/Corner
	90-115	90-110				Lap/Filler
3/16" (4.8mm)	115-135	100-125	3/32" (2.4mm)	1/8" (3.2mm)	21 CFH (10 LPM)	Butt/Corner
	140-165	125-150				Lap/Filler
1/4" (6.4mm)	160-175	135-160	1/8" (3.2mm)	5/32" (4.0mm)	21 CFH (10 LPM)	Butt/Corner
	170-200	160-180				Lap/Filler

4.12 Arc Welding Practice

The techniques used for arc welding are almost identical regardless of what types of metals are being joined. Naturally enough, different types of electrodes would be used for different metals as described in the preceding section.

4.13 Welding Position

The electrodes dealt with in this publication can be used in most positions, i.e. they are suitable for welding in flat, horizontal, vertical and overhead positions. Numerous applications call for welds to be made in positions intermediate between these. Some of the common types of welds are shown in Figures 4-2 through 4-9.

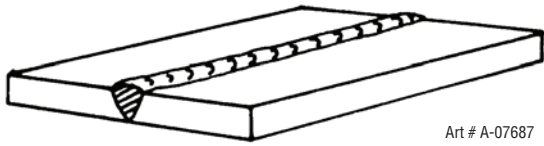

Figure 4-2: Flat position, down hand butt weld

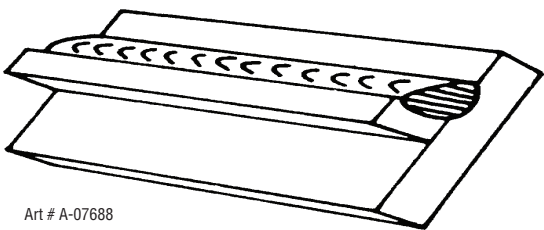

Figure 4-3: Flat position, gravity fillet weld

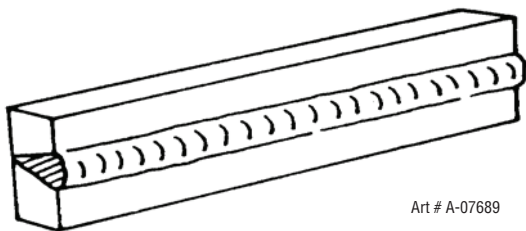

Figure 4-4: Horizontal position, butt weld

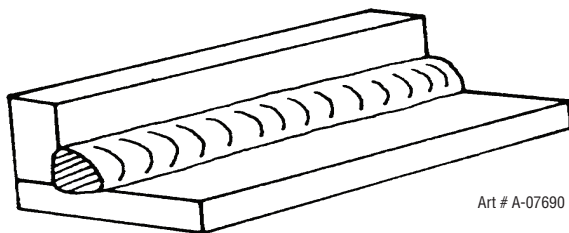

Figure 4-5: Horizontal - Vertical (HV) position

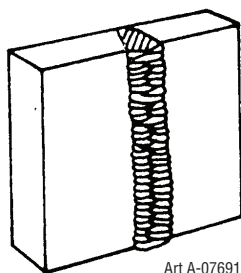

Figure 4-6: Vertical position, butt weld

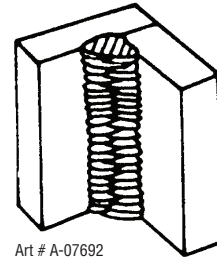

Figure 4-7: Vertical position, fillet weld

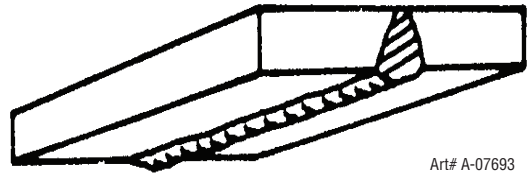

Figure 4-8: Overhead position, butt weld

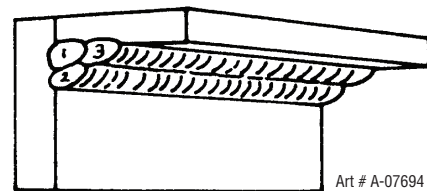
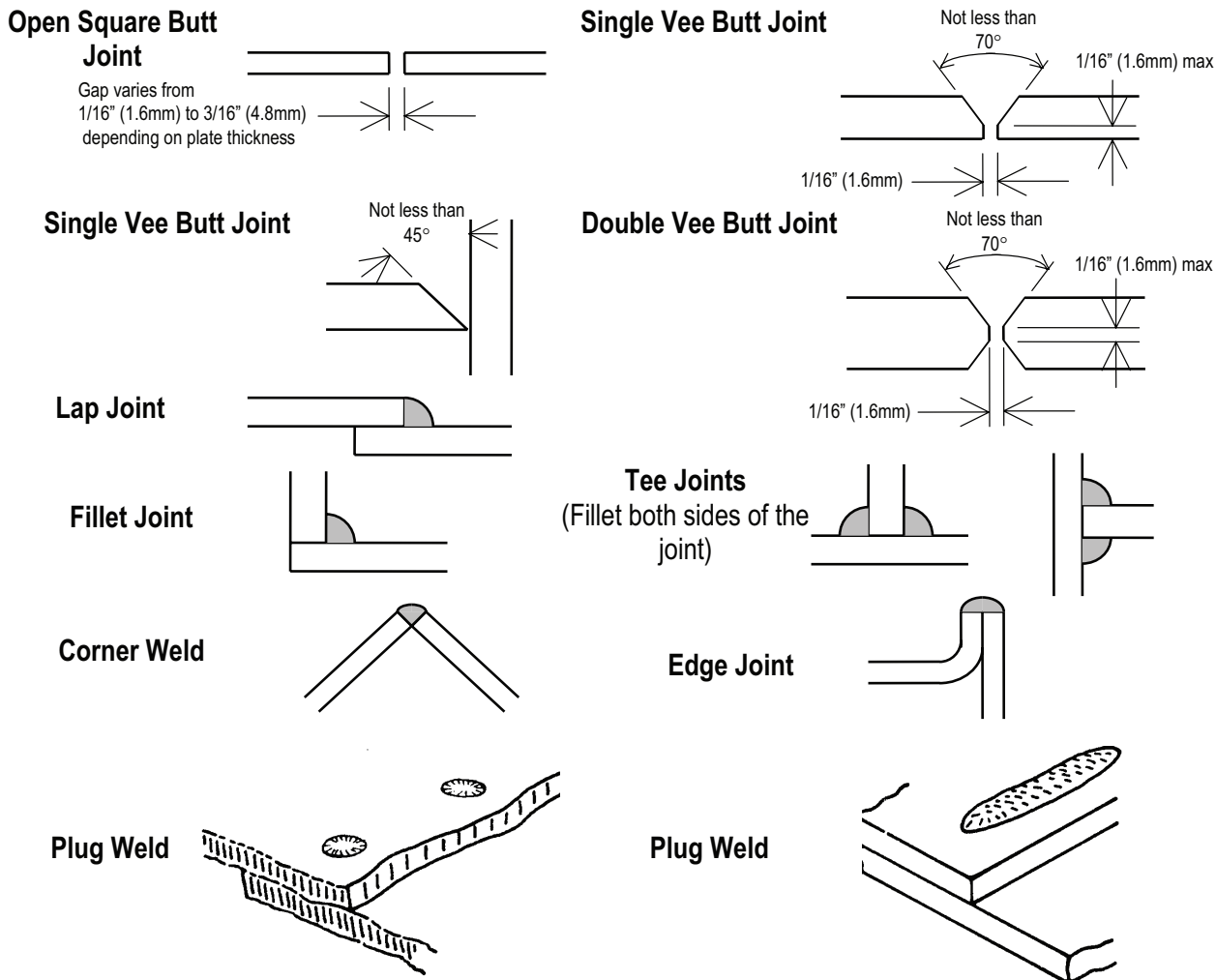

Figure 4-9: Overhead position, fillet weld

4.14 Joint Preparations

In many cases, it will be possible to weld steel sections without any special preparation. For heavier sections and for repair work on castings, etc., it will be necessary to cut or grind an angle between the pieces being joined to ensure proper penetration of the weld metal and to produce sound joints.

In general, surfaces being welded should be clean and free of rust, scale, dirt, grease, etc. Slag should be removed from oxy-cut surfaces. Typical joint designs are shown in Figure 4-10.



Art # A-07695_AC

Figure 4-10: Typical joint designs for arc welding

4.15 Arc Welding Technique

A Word to Beginners

For those who have not yet done any welding, the simplest way to commence is to run beads on a piece of scrap plate. Use mild steel plate about 1/4" (6.0mm) thick and a 1/8" (3.2mm) electrode. Clean any paint, loose scale or grease off the plate and set it firmly on the work bench so that welding can be carried out in the down hand position. Make sure that the work clamp is making good electrical contact with the work, either directly or through the work table. For light gauge material, always clamp the work lead directly to the job, otherwise a poor circuit will probably result.

4.16 The Welder

Place yourself in a comfortable position before beginning to weld. Get a seat of suitable height and do as much work as possible sitting down. Do not hold your body tense. A taut attitude of mind and a tensed body will soon make you feel tired. Relax and you will find that the job becomes much easier. You can add much to your peace of mind by wearing a leather apron and gauntlets. You won't be worrying then about being burnt or sparks setting alight to your clothes.

Place the work so that the direction of welding is across, rather than to or from, your body. The electrode holder lead should be clear of any obstruction so that you can move your arm freely along as the electrode burns down. If the lead is slung over your shoulder, it allows greater freedom of movement and takes a lot of weight off your hand. Be sure the insulation on your cable and electrode holder is not faulty, otherwise you are risking an electric shock.

4.17 Striking the Arc

Practice this on a piece of scrap plate before going on to more exacting work. You may at first experience difficulty due to the tip of the electrode "sticking" to the work piece. This is caused by making too heavy a contact with the work and failing to withdraw the electrode quickly enough. A low amperage will accentuate it. This freezing-on of the tip may be overcome by scratching the electrode along the plate surface in the same way as a match is struck. As soon as the arc is established, maintain a $1/16"$ (1.6mm) to $1/8"$ (3.2mm) gap between the burning electrode end and the parent metal. Draw the electrode slowly along as it melts down.

Another difficulty you may meet is the tendency, after the arc is struck, to withdraw the electrode so far that the arc is broken again. A little practice will soon remedy both of these faults.

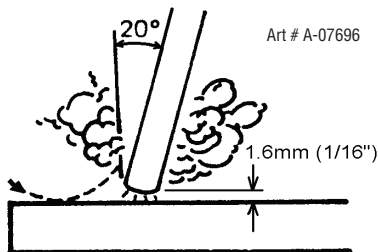

Figure 4-11: Striking an arc

4.18 Arc Length

The securing of an arc length necessary to produce a neat weld soon becomes almost automatic. You will find that a very long arc produces a crackling or spluttering noise and the weld metal comes across in large, irregular blobs. The weld bead is flattened and spatter increases. A short arc is essential if a high quality weld is to be obtained although if it is too short there is the danger of it being blanketed by slag and the electrode tip being solidified in. If this should happen, give the electrode a quick twist back over the weld to detach it. Contact or "touch-weld" electrodes such as E7014 do not stick in this way, and make welding much easier.

4.19 Rate of Travel

After the arc is struck, your next concern is to maintain it, and this requires moving the electrode tip towards the molten pool at the same rate as it is melting away. At the same time, the electrode has to move along the plate to form a bead. The electrode is directed at the weld pool at about 20° from the vertical. The rate of travel has to be adjusted so that a well-formed bead is produced.

If the travel is too fast, the bead will be narrow and strung out and may even be broken up into individual globules. If the travel is too slow, the weld metal piles up and the bead will be too large.

4.20 Making Welded Joints

Having attained some skill in the handling of an electrode, you will be ready to go on to make up welded joints.

A. Butt Welds

Set up two plates with their edges parallel, as shown in Figure 4-12, allowing $1/16"$ (1.6mm) to $3/32"$ (2.4mm) gap between them and tack weld at both ends. This is to prevent contraction stresses from the cooling weld metal pulling the plates out of alignment. Plates thicker than $1/4"$ (6.0mm) should have their mating edges bevelled to form a 70° to 90° included angle. This allows full penetration of the weld metal to the root. Using a $1/8"$ (3.2mm) E7014 electrode at 120 amps, deposit a run of weld metal on the bottom of the joint.

Do not weave the electrode, but maintain a steady rate of travel along the joint sufficient to produce a well-formed bead. At first you may notice a tendency for undercut to form, but keeping the arc length short, the angle of the electrode at about 20° from vertical, and the rate of travel not too fast, will help eliminate this. The electrode needs to be moved along fast

C. Vertical Welds

1. Vertical Up

Tack weld a three feet length of angle iron to your work bench in an upright position. Use a 1/8" (3.2mm) E7014 electrode and set the current at 120 amps. Make yourself comfortable on a seat in front of the job and strike the arc in the corner of the fillet. The electrode needs to be about 10° from the horizontal to enable a good bead to be deposited. Refer Figure 4-16. Use a short arc, and do not attempt to weave on the first run. When the first run has been completed de-slag the weld deposit and begin the second run at the bottom. This time a slight weaving motion is necessary to cover the first run and obtain good fusion at the edges. At the completion of each side motion, pause for a moment to allow weld metal to build up at the edges, otherwise undercut will form and too much metal will accumulate in the centre of the weld. Figure 4-17 illustrates multi-run technique and Figure 4-18 shows the effects of pausing at the edge of weave and of weaving too rapidly.

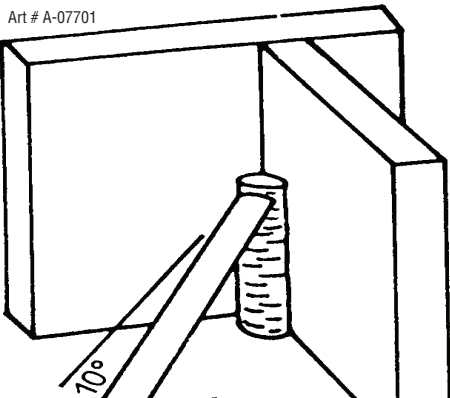

Figure 4-16: Single run vertical fillet weld

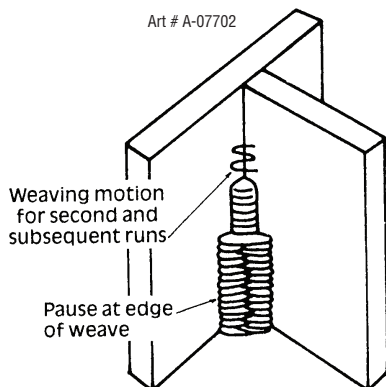

Figure 4-17: Multi run vertical fillet weld

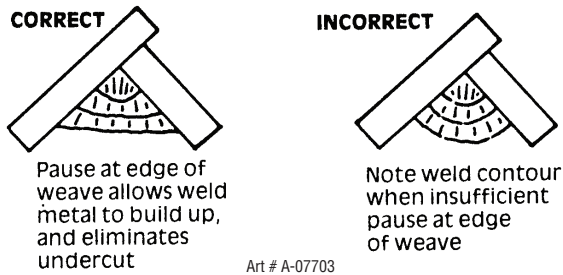

Figure 4-18: Examples of vertical fillet welds

2. Vertical Down

The E7014 electrode makes welding in this position particularly easy. Use a 1/8" (3.2mm) electrode at 120 amps. The tip of the electrode is held in light contact with the work and the speed of downward travel is regulated so that the tip of the electrode just keeps ahead of the slag. The electrode should point upwards at an angle of about 45°.

3. Overhead Welds

Apart from the rather awkward position necessary, overhead welding is not much more difficult than down hand welding. Set up a specimen for overhead welding by first tacking a length of angle iron at right angles to another piece of angle iron or a length of waste pipe. Then tack this to the work bench or hold in a vice so that the specimen is positioned in the overhead position as shown in the sketch. The electrode is held at 45° to the horizontal and tilted 10° in the line of travel (Figure 4-19). The tip of the electrode may be touched lightly on the metal, which helps to give a steady run. A weave technique is not advisable for overhead fillet welds. Use a 1/8" (3.2mm) E6012 electrode at 120 amps, and deposit the first run by simply drawing the electrode along at a steady rate. You will notice that the weld deposit is rather convex, due to the effect of gravity before the metal freezes.

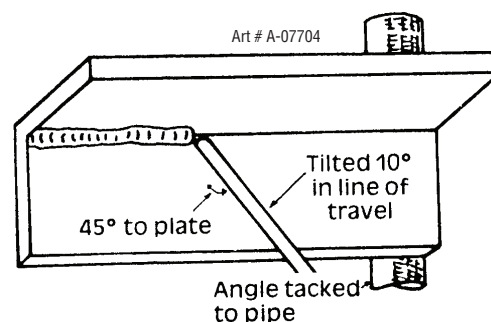

Figure 4-19: Overhead fillet weld

4.21 Distortion

Distortion in some degree is present in all forms of welding. In many cases it is so small that it is barely perceptible, but in other cases allowance has to be made before welding commences for the distortion that will subsequently occur. The study of distortion is so complex that only a brief outline can be attempted here.

4.22 The Cause of Distortion

Distortion is caused by:

A. Contraction of Weld Metal:

Molten steel shrinks approximately 11% in volume on cooling to room temperature. This means that a cube of molten metal would contract approximately 2.2% in each of its three dimensions. In a welded joint, the metal becomes attached to the side of the joint and cannot contract freely. Therefore, cooling causes the weld metal to flow plastically, that is, the weld itself has to stretch if it is to overcome the effect of shrinking volume and still be attached to the edge of the joint. If the restraint is excessive, e.g. a heavy section of plate, then the weld metal may crack. Even in cases where the weld metal does not crack, there will still remain stresses "locked-up" in the structure. If the joint material is relatively weak, for example, a butt joint in 5/64" (2.0mm) sheet, the contracting weld metal may cause the sheet to become distorted.

B. Expansion and Contraction of Parent Metal in the Fusion Zone:

While welding is proceeding, a relatively small volume of the adjacent plate material is heated to a very high temperature and attempts to expand in all directions. It is able to do this freely at right angles to the surface of the plate (i.e., "through the weld"), but when it attempts to expand "across the weld" or "along the weld", it meets considerable resistance, and to fulfil the desire for continued expansion, it has to deform plastically, that is, the metal adjacent to the weld is at a high temperature and hence rather soft, and, by expanding, pushes against the cooler, harder metal further away, and tends to bulge (or is "upset"). When the weld area begins to cool, the "upset" metal attempts to contract as much as it expanded, but, because it has been "upset", it does not resume its former shape, and the contraction of the new shape exerts a strong pull on adjacent metal. Several things can then happen.

The metal in the weld area is stretched (plastic deformation), the job may be pulled out of shape by the powerful contraction stresses (distortion), or the weld may crack, in any case, there will remain "locked-up" stresses in the job. Figures 4-20 and 4-21 illustrate how distortion is created.

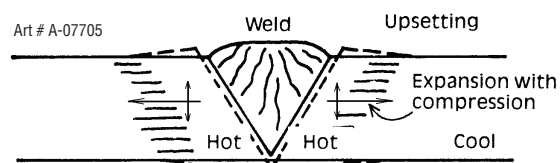

Figure 4-20: Parent metal expansion

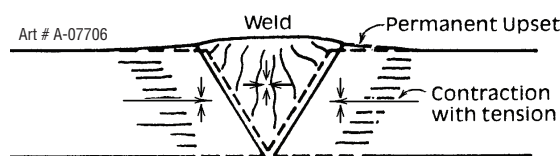

Figure 4-21: Parent metal contraction

4.23 Overcoming Distortion Effects

There are several methods of minimizing distortion effects.

A. Peening

This is done by hammering the weld while it is still hot. The weld metal is flattened slightly and because of this the tensile stresses are reduced a little. The effect of peening is relatively shallow, and is not advisable on the last layer.

B. Distribution of Stresses

Distortion may be reduced by selecting a welding sequence which will distribute the stresses suitably so that they tend to cancel each other out. See Figures 4-25 through 4-28 for various weld sequences. Choice of a suitable weld sequence is probably the most effective method of overcoming distortion, although an unsuitable sequence may exaggerate it. Simultaneous welding of both sides of a joint by two welders is often successful in eliminating distortion.

C. Restraint of Parts

Forcible restraint of the components being welded is often used to prevent distortion. Jigs, positions, and tack welds are methods employed with this in view.

D. Presetting

It is possible in some cases to tell from past experience or to find by trial and error (or less frequently, to calculate) how much distortion will take place in a given welded structure. By correct pre-setting of the components to be welded, constructional stresses can be made to pull the parts into correct alignment. A simple example is shown in Figure 4-22.

E. Preheating

Suitable preheating of parts of the structure other than the area to be welded can be sometimes used to reduce distortion. Figure 4-23 shows a simple application. By removing the heating source from B and C as soon as welding is completed, the sections B and C will contract at a similar rate, thus reducing distortion.

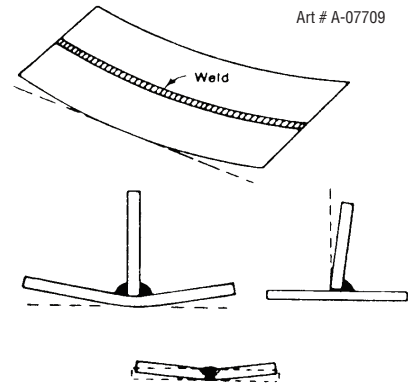

Figure 4-24: Examples of distortion

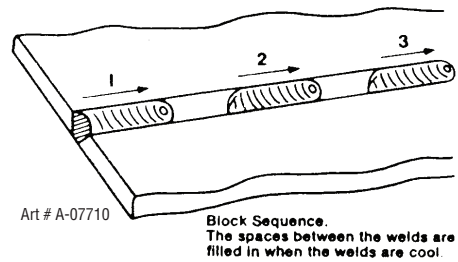

Figure 4-25: Welding sequence

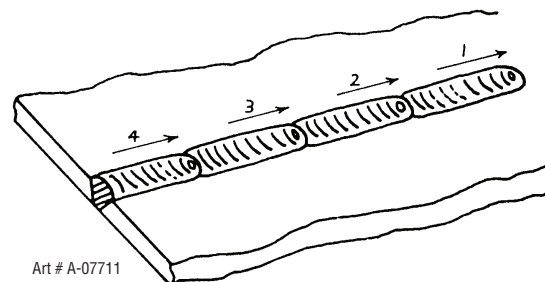

Figure 4-26: Step back sequence

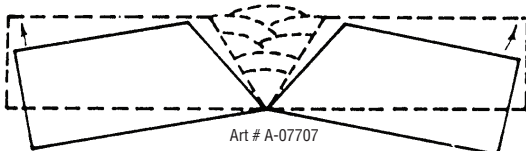
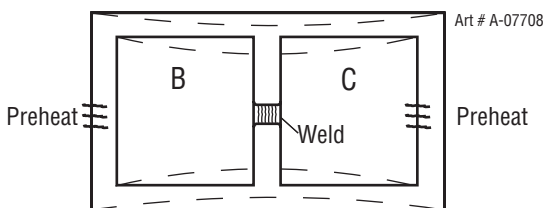

Figure 4-22: Principle of presetting



Dotted lines show effect if no preheat is used

Figure 4-23: Reduction of distortion by preheating

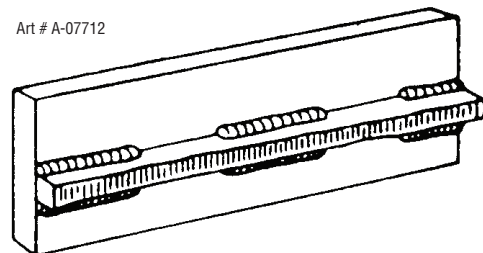

Figure 4-27: Chain intermittent welding

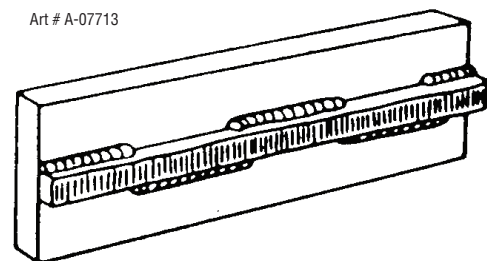

Figure 4-28: Staggered intermittent welding

**SECTION 5:
SERVICE**

5.01 ROUTINE MAINTENANCE AND INSPECTION

The only routine maintenance required for the power supply is a thorough cleaning and inspection, with the frequency depending on the usage and the operating environment.

To clean the unit, open the enclosure and use a vacuum cleaner to remove any accumulated dirt and dust. The unit should also be wiped clean, if necessary; with solvents that are recommended for cleaning electrical apparatus.



WARNING

There are extremely dangerous voltages and power levels present inside this product. Disconnect primary power at the source before opening the enclosure. Wait at least two minutes before opening the enclosure to allow the primary capacitors to discharge.



CAUTION

Do not blow air into the power supply during cleaning. Blowing air into the unit can cause metal particles to interfere with sensitive electrical components and cause damage to the unit.



Warning!

Disconnect input power before maintaining.

Maintain more often if used under severe conditions

Each Use

Visual check of regulator and pressure

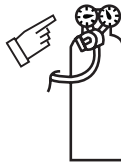

Visual check of torch Consumable parts

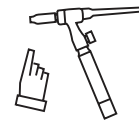

Weekly

Visually inspect the torch body and consumables

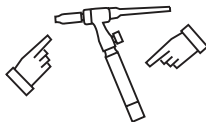

Visually inspect the cables and leads. Replace as needed

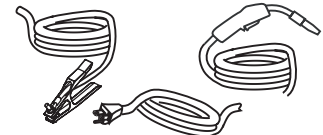

3 Months

Replace all broken parts

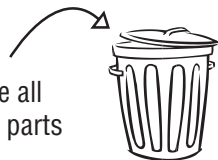

Clean exterior of power supply

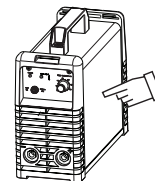

6 Months

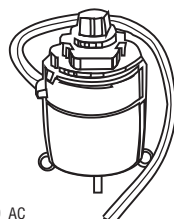

Art # A-08549_AC

Bring the unit to an authorized Thermal Arc Service Centre to remove any accumulated dirt and dust from the interior. This may need to be done more frequently under exceptionally dirty conditions.

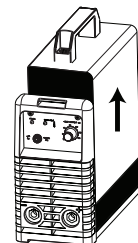

5.02 STICK WELDING PROBLEMS

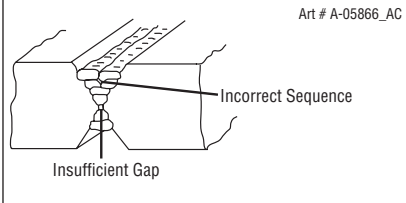
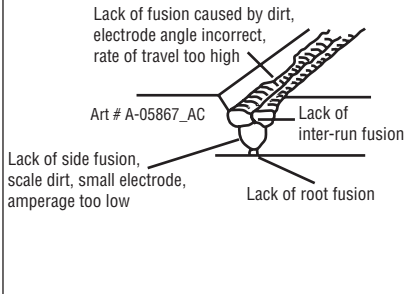
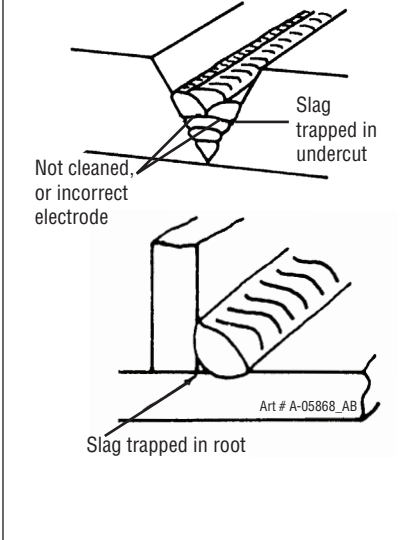
Description	Possible Cause	Remedy
<p>1. Gas pockets or voids in weld metal (Porosity).</p>	<p>A. Electrodes are damp. B. Welding current is too high. C. Surface impurities such as oil, grease, paint, etc.</p>	<p>A. Dry electrodes before use. B. Reduce welding current. C. Clean joint before welding</p>
<p>2. Crack occurring in weld metal soon after solidification commences.</p>	<p>A. Rigidity of joint. B. Insufficient throat thickness. C. Cooling rate is too high.</p>	<p>A. Redesign to relieve weld joint of severe stresses or use crack resistance electrodes. B. Travel slightly slower to allow greater build up in throat. C. Preheat plate and cool slowly.</p>
<p>3. A gap is left by failure of the weld metal to fill the root of the weld.</p> 	<p>A. Welding current is too low. B. Electrode too large for joint. C. Insufficient gap. D. Incorrect sequence.</p>	<p>A. Increase welding current B. Use smaller diameter electrode. C. Allow wider gap. D. Use correct build-up sequence.</p>
<p>4. Portions of the weld run do not fuse to the surface of the metal or edge of the joint</p> 	<p>A. Small electrodes used on heavy cold plate. B. Welding current is too low. C. Wrong electrode angle. D. Travel speed of electrode is too high. E. Scale or dirt on joint surface.</p>	<p>A. Use larger electrodes and pre-heat the plate. B. Increase welding current C. Adjust angle so the welding arc is directed more into the base metal D. Reduce travel speed of electrode E. Clean surface before welding.</p>
<p>5. Non-metallic particles are trapped in the weld metal (slag inclusion).</p> 	<p>A. Non-metallic particles may be trapped in undercut from previous run. B. Joint preparation too restricted. C. Irregular deposits allow slag to be trapped. D. Lack of penetration with slag trapped beneath weld bead. E. Rust or mill scale is preventing full fusion. F. Wrong electrode for position in which welding is done.</p>	<p>A. If bad undercut is present, clean slag out and cover with a run from a smaller diameter electrode. B. Allow for adequate penetration and room for cleaning out the slag. C. If very bad, chip or grind out irregularities. D. Use smaller electrode with sufficient current to give adequate penetration. Use suitable tools to remove all slag from corners. E. Clean joint before welding. F. Use electrodes designed for position in which welding is done, otherwise proper control of slag is difficult.</p>

5.03 TIG WELDING PROBLEMS

Weld quality is dependent on the selection of the correct consumables, maintenance of equipment and proper welding technique

Description	Possible Cause	Remedy
1. Excessive beard build-up or poor penetration or poor fusion at edges of weld.	Welding current is too low	Increase weld current and/or change joint preparation.
2. Weld bead too wide and flat or undercut at edges of weld or excessive burn through.	Welding current is too high.	Decrease welding current.
3. Weld bead too small or insufficient penetration or ripples in bead are widely spaced apart.	Travel speed too fast.	Reduce travel speed.
4. Weld bead too wide or excessive bead build up or excessive penetration in butt joint.	Travel speed is too slow.	Increase travel speed.
5. Uneven leg length in fillet joint.	Wrong placement of filler rod.	Re-position filler rod.
6. Electrode melts when arc is struck.	Electrode is connected to the “+” Positive Output Terminal.	Connect the electrode to the “-“ Negative Output Terminal.
7. Dirty weld pool.	A. Electrode contaminated through contact with work piece or filler rod material. B. Gas contaminated with air.	A. Clean the electrode by grinding contaminates off. B. Check gas lines for cuts and loose fitting or change gas cylinder.
8. Poor weld finish.	Inadequate shielding gas.	Increase gas flow or check gas line for problems
9. Arc flutters during TIG welding.	Tungsten electrode is too large for the welding current.	Select the right size electrode. Refer to section Tungsten Electrode Current Ranges.
10. Welding arc cannot be established.	A. Work clamp is not connected to the work piece or the work/torch leads are not connected to the correct welding terminals. B. Torch lead is disconnected. C. Gas flow incorrectly set, cylinder empty or the torch valve is off.	A. Connect the work clamp to the work piece or connect the work/torch leads to the correct welding terminals. B. Connect it to the “-“ Negative Output Terminal. C. Select the right flow rate, change cylinder or turn torch valve on.
11. Electrode melts or oxidizes when an arc is struck.	A. No gas is flowing to welding region. B. Torch is clogged with dust. C. Gas hose is cut. D. Gas passage contains impurities. E. Gas regulator turned off. F. Torch valve is turned off. G. The electrode is too small for the welding current.	A. Check the gas lines for kinks or breaks or cylinder contains gas. B. Clean torch. C. Replace gas hose. D. Disconnect gas hose from torch then raise gas pressure and blow out impurities. E. Turn on. F. Turn on. G. Increase electrode diameter or reduce the welding current.

TIG Welding Problems Continued

Description	Possible Cause	Remedy
12. Arc start is not smooth.	A. Tungsten electrode is too large for the welding current. B. The wrong electrode is being used for the welding job. C. Gas flow rate is too high. D. Incorrect shield gas is being used. E. Poor work clamp connection to work piece.	A. Refer to section Tungsten Electrode Current Ranges for the correct size. B. Refer to section Tungsten Electrode Types for the correct electrode type. C. Select the correct flow rate for the welding job. D. Use 100% argon for TIG welding. E. Improve connection to work piece.



WARNING

There are extremely dangerous voltages and power levels present inside this product. Do not attempt to repair unless you are an Accredited Thermal Arc Service Agent and you have had training in power measurements and troubleshooting techniques. If major complex subassemblies are faulty, then the Welding Power Source must be returned to an Accredited Thermal Arc Service Agent for repair.

5.04 POWER SOURCE PROBLEMS

Description	Possible Cause	Remedy
1. The welding arc cannot be established.	A. The Primary supply voltage has not been switched ON. B. The Welding Power Source switch is switched OFF. C. Loose connections internally.	A. Switch ON the Primary supply voltage. B. Switch ON the Welding Power Source. C. Have an Accredited Thermal Arc Service Provider repair the connection.
2. Maximum output welding current cannot be achieved with nominal Mains voltage.	Defective control circuit.	Have an Accredited Thermal Arc Service Provider inspect then repair the welder.
3. Welding current reduces when welding.	Poor work lead connection to the work piece.	Ensure that the work lead has a positive electrical connection to the work piece.
4. TIG electrode melts when arc is struck.	TIG torch is connected to the (+) VE terminal.	Connect the TIG torch to the (-) VE terminal.
5. Arc flutters during TIG welding.	Tungsten electrode is too large for the welding current.	Select the correct size of tungsten electrode.
6. No High Frequency is produced.	A. Process selection switch is set to Manual Arc or Lift TIG Mode.	A. Set process Selection Switch to HF TIG Mode.
	B. Torch Trigger Switch lead is disconnected or switch/lead is faulty.	B. Reconnect or repair TIG torch trigger switch/lead.
	C. High Frequency Spark Gap too wide or short circuited.	C. Have an Accredited Thermal Arc Service Provider adjust spark gap to be 0.5 – 0.6mm.
7. No Gas Flow when the TIG Torch Trigger Switch is depressed.	A. Gas Regulator is turned off.	A. Turn Gas Regulator on.
	B. Gas Hose is cut.	B. Replace Gas Hose.
	C. Gas passage contains impurities.	C. Disconnect Gas Hose from the rear of the power source then raise the gas pressure and blow out impurities.
	D. Torch Trigger Switch lead is disconnected or switch/lead is faulty.	D. Reconnect or repair TIG torch trigger switch/lead.

APPENDIX 1: REPLACEMENT PARTS

Description	Part No.
Cooling Fan AM 175TE	W7003009
Rectifier,700V,50A, AM175TE	W7003010
Current Sensor AM 175TE	W7003013
Output Terminal AM 175TE	W7003020
PCB Control AM 175TE	W7003029
PCB Power AM 175TE	W7003030
PCB Front Panel AM 175TE	W7003031
Inductor AM 175TE	W7003032
Gas Solenoid AM 175TE	W7003033
H.F. Points AM 175TE	W7003034
Gas Outlet AM 175TE	W7003035
Control Socket 8 pin AM 175TE	W7003036

APPENDIX 2: OPTIONS AND ACCESSORIES

Part No.	Description
W4012700	Torch TIG,17,10ft,50mm Dinse
W7003038	TIG Torch Repair Kit, AM 175TE
W4012800	Case Toolbox,175TE with labels fitted
W4011900	Claret Helmet,Variable shade 9-13 Auto-Darkening
W4012000	Black w/Graphics Helmet,Variable shade 9-13 Auto-Darkening

NOTES

NOTES

NOTES

LIMITED WARRANTY & WARRANTY SCHEDULE

In accordance with the warranty periods stated below, Thermadyne guarantees the proposed product to be free from defects in material or workmanship when operated in accordance with the written instructions as defined in this operating manual.

Thermadyne welding products are manufactured for use by commercial and industrial users and trained personnel with experience in the use and maintenance of electrical welding and cutting equipment.

Thermadyne will repair or replace, at its discretion, any warranted parts or components that fail due to defects in material or workmanship within the warranty period. The warranty period begins on the date of sale to the end user.

<i>Welding Equipment - Limited Warranty Period</i>	
<i>Product</i>	<i>Period</i>
<i>ArcMaster 175 TE</i>	<i>2 Years</i>
<i>TIG Torch, Electrode holder and work lead</i>	<i>30 Days</i>

If warranty is being sought Thermadyne must be notified in writing within 30 days of the failure and at such time we will make arrangements to fulfil the warranty claim. Please contact your Thermadyne product supplier for the warranty repair procedure.

Thermadyne warranty will not apply to:

- Equipment that has been modified by any other party other than Thermadyne's own service personnel or with prior written consent obtained from Thermadyne service department (UK).
- Equipment that has been used beyond the specifications established in the operating manual.
- Installation not in accordance with the installation/operating manual.
- Any product that has been subjected to abuse, misuse, negligence, accident, improper care and/or maintenance including lack of lubrication, maintenance and protection, will be refused warranty.
- Failure to clean and maintain the machine as set forth in the operating, installation or service manual.

Within this operating manual are details regarding the maintenance necessary to ensure trouble free operation. This manual also offers basic troubleshooting, operational and technical details including application usage.

Using this manual correctly will ensure the quickest time possible for resolving any technical questions, application issues or defects with your Thermadyne product.

You may also wish to visit our web site www.thermadyne.com select your product class and then select literature. Here you will find documentation including:

- Operator manuals
- Service manuals
- Product guides

Alternatively please contact your Thermadyne distributor and speak with a technical representative.

NOTE

Warranty repairs must be performed by either a Thermadyne Service Centre, a Thermadyne distributor or an Authorised Service Agent approved by the Company.



WORLD HEADQUARTERS: 16052 Swingley Ridge Road, Suite 300 • St. Louis, Missouri 63017 U.S.A.

Customer Care UK: +44 (0)1257 261 755 / Fax: +44 (0)1257 224 800
Customer Care Italy +39 02 36546801 / Fax: +39 02 36546480
www.thermadyne.com

A Global Cutting & Welding Market Leader™

THE AMERICAS

Denton, TX USA
U.S. Customer Care
Ph: 1-800-426-1888 (tollfree)
Fax: 1-800-535-0557 (tollfree)
International Customer Care
Ph: 1-940-381-1212
Fax: 1-940-483-8178

Miami, FL USA
Sales Office, Latin America
Ph: 1-954-727-8371
Fax: 1-954-727-8376

Oakville, Ontario, Canada
Canada Customer Care
Ph: 1-905-827-4515
Fax: 1-800-588-1714 (tollfree)

EUROPE

Chorley, United Kingdom
Customer Care
Ph: +44 1257-261755
Fax: +44 1257-224800

Milan, Italy
Customer Care
Ph: +39 0236546801
Fax: +39 0236546840

ASIA/PACIFIC

Cikarang, Indonesia
Customer Care
Ph: 6221-8990-6095
Fax: 6221-8990-6096

Rawang, Malaysia
Customer Care
Ph: +603 6092-2988
Fax: +603 6092-1085

Melbourne, Australia
Australia Customer Care
Ph: 1300-654-674 (tollfree)
Ph: 61-3-9474-7400
Fax: 61-3-9474-7391
International
Ph: 61-3-9474-7508
Fax: 61-3-9474-7488

Shanghai, China
Sales Office
Ph: +86 21-64072626
Fax: +86 21-64483032

Singapore
Sales Office
Ph: +65 6832-8066
Fax: +65 6763-5812